





<p><b>Description</b></p> <p>The Power MOSFET is fabricated using the advanced planer VDMOS technology. The resulting device has low conduction resistance, superior switching performance and high avalanche energy.</p> <p><b>Features</b></p> <ul style="list-style-type: none"> <li>◆ Low <math>R_{DS(on)}</math></li> <li>◆ Low gate charge (typ. <math>Q_g = 31.4</math> nC)</li> <li>◆ 100% UIS tested</li> <li>◆ RoHS compliant</li> </ul> <p><b>Applications</b></p> <ul style="list-style-type: none"> <li>◆ Power factor correction.</li> <li>◆ Switched mode power supplies.</li> <li>◆ LED driver.</li> </ul>	<p><b>Product Summary</b></p> <p><math>V_{DSS}</math>                      600V</p> <p><math>I_D</math>                              10A</p> <p><math>R_{DS(on),max}</math>              0.9<math>\Omega</math></p> <p><math>Q_{g,typ}</math>                        31.4 nC</p> <div style="display: flex; justify-content: space-around; align-items: center;"> <div style="text-align: center;">  <p>TO-262</p> </div> <div style="text-align: center;">  <p>TO-263</p> </div> <div style="text-align: center;">  <p>TO-220F</p> </div> </div> <div style="display: flex; justify-content: space-around; align-items: center;"> <div style="text-align: center;">  <p>TO-220C</p> </div> <div style="text-align: center;">  <p>Schematic</p> </div> </div>
--	--

### Absolute Maximum Ratings

Parameter	Symbol	Value	Unit
Drain-Source Voltage	$V_{DSS}$	600	V
Continuous drain current ( $T_C = 25^\circ\text{C}$ )	$I_D$	10	A
( $T_C = 100^\circ\text{C}$ )		6.3	A
Pulsed drain current <sup>1)</sup>	$I_{DM}$	40	A
Gate-Source voltage	$V_{GSS}$	$\pm 30$	V
Avalanche energy, single pulse <sup>2)</sup>	$E_{AS}$	500	mJ
Peak diode recovery $dv/dt$ <sup>3)</sup>	$dv/dt$	5	V/ns
Power Dissipation C TO-220F ( $T_C = 25^\circ\text{C}$ )	$P_D$	40	W
Derate above $25^\circ\text{C}$		0.32	W/ $^\circ\text{C}$
Power Dissipation C TO-220\TO-262\ TO-263 ( $T_C = 25^\circ\text{C}$ )	$P_D$	130	W
Derate above $25^\circ\text{C}$		1.04	W/ $^\circ\text{C}$
Operating junction and storage temperature range	$T_J, T_{STG}$	-55 to +150	$^\circ\text{C}$
Continuous diode forward current	$I_S$	10	A
Diode pulse current	$I_{S,pulse}$	40	A

### Thermal Characteristics

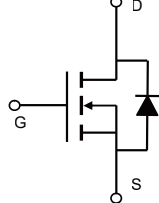
Parameter	Symbol	Value		Unit
		C TO-220F	C TO-220\TO-251\TO-252	
Thermal resistance, Junction-to-case	$R_{\theta JC}$	3.13	0.96	$^\circ\text{C}/\text{W}$
Thermal resistance, Junction-to-ambient	$R_{\theta JA}$	110	62.5	$^\circ\text{C}/\text{W}$

**Package Marking and Ordering Information**

Device	Device Package	Marking	Units/Tube	Units/Reel
VSM10N60-T62	TO-262	VSM10N60-T62	50	
VSM10N60-T3	TO-263	VSM10N60-T3	50	
VSM10N60-TF	TO-220F	VSM10N60-TF		800
VSM10N60-TC	TO-220C	VSM10N60-TC	50	

**Electrical Characteristics**
 $T_c = 25^\circ\text{C}$  unless otherwise noted

Parameter	Symbol	Test Condition	Min.	Typ.	Max.	Unit
<b>Static characteristics</b>						
Drain-source breakdown voltage	$BV_{DSS}$	$V_{GS}=0\text{ V}, I_D=0.25\text{ mA}$	600	-	-	V
Gate threshold voltage	$V_{GS(th)}$	$V_{DS}=V_{GS}, I_D=0.25\text{ mA}$	2	-	4	V
Drain cut-off current	$I_{DSS}$	$V_{DS}=600\text{ V}, V_{GS}=0\text{ V},$ $T_j = 25^\circ\text{C}$ $T_j = 125^\circ\text{C}$	-	-	1	$\mu\text{A}$
Gate leakage current, Forward	$I_{GSSF}$	$V_{GS}=30\text{ V}, V_{DS}=0\text{ V}$	-	-	100	nA
Gate leakage current, Reverse	$I_{GSSR}$	$V_{GS}=-30\text{ V}, V_{DS}=0\text{ V}$	-	-	-100	nA
Drain-source on-state resistance	$R_{DS(on)}$	$V_{GS}=10\text{ V}, I_D=5\text{ A}$	-	0.65	0.9	$\Omega$
<b>Dynamic characteristics</b>						
Input capacitance	$C_{iss}$	$V_{DS} = 25\text{ V}, V_{GS} = 0\text{ V},$ $f = 1\text{ MHz}$	-	1620	-	pF
Output capacitance	$C_{oss}$		-	138.2	-	
Reverse transfer capacitance	$C_{rss}$		-	6.6	-	
Turn-on delay time	$t_{d(on)}$	$V_{DD} = 300\text{ V}, I_D = 10\text{ A}$ $R_G = 10\ \Omega, V_{GS}=15\text{ V}$	-	15	-	ns
Rise time	$t_r$		-	32.6	-	
Turn-off delay time	$t_{d(off)}$		-	61.6	-	
Fall time	$t_f$		-	14.5	-	
<b>Gate charge characteristics</b>						
Gate to source charge	$Q_{gs}$	$V_{DD}=480\text{ V}, I_D=10\text{ A},$ $V_{GS}=0\text{ to }10\text{ V}$	-	8.3	-	nC
Gate to drain charge	$Q_{gd}$		-	10.2	-	
Gate charge total	$Q_g$		-	31.4	-	
Gate plateau voltage	$V_{plateau}$		-	5	-	V
<b>Reverse diode characteristics</b>						
Diode forward voltage	$V_{SD}$	$V_{GS}=0\text{ V}, I_F=10\text{ A}$	-	-	1.5	V
Reverse recovery time	$t_{rr}$	$V_R=300\text{ V}, I_F=10\text{ A},$ $di_F/dt=100\text{ A}/\mu\text{s}$	-	370	-	ns
Reverse recovery charge	$Q_{rr}$		-	3.14	-	$\mu\text{C}$
Peak reverse recovery current	$I_{rrm}$		-	17	-	A

**Notes:**

- Pulse width limited by maximum junction temperature.
- $L=10\text{mH}, I_{AS} = 10\text{ A}$ , Starting  $T_j= 25^\circ\text{C}$ .
- $I_{SD} = 10\text{ A}$ ,  $di/dt \leq 100\text{ A}/\mu\text{s}$ ,  $V_{DD} \leq BV_{DS}$ , Starting  $T_j= 25^\circ\text{C}$ .

## Electrical Characteristics Diagrams

Figure 1. Typical Output Characteristics

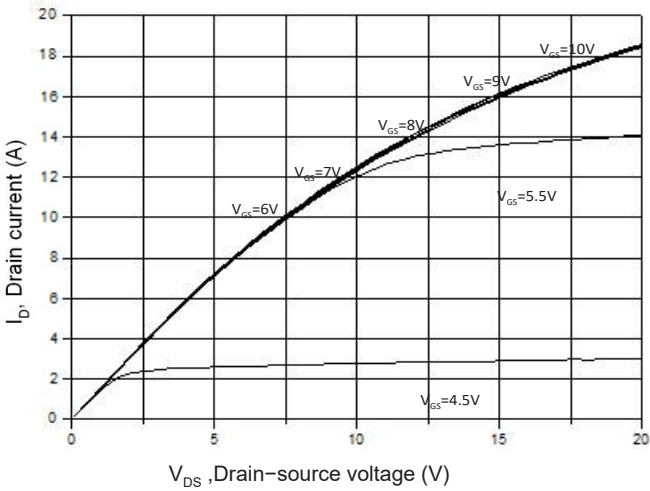

Figure 2. Transfer Characteristics

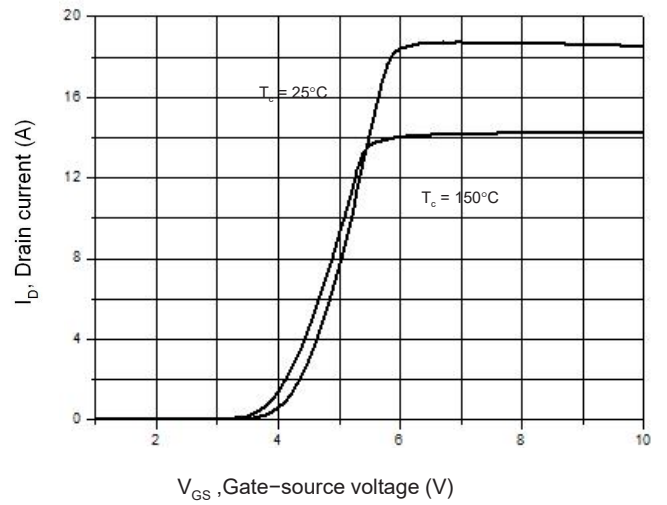

Figure 3. On-Resistance Variation vs. Drain Current

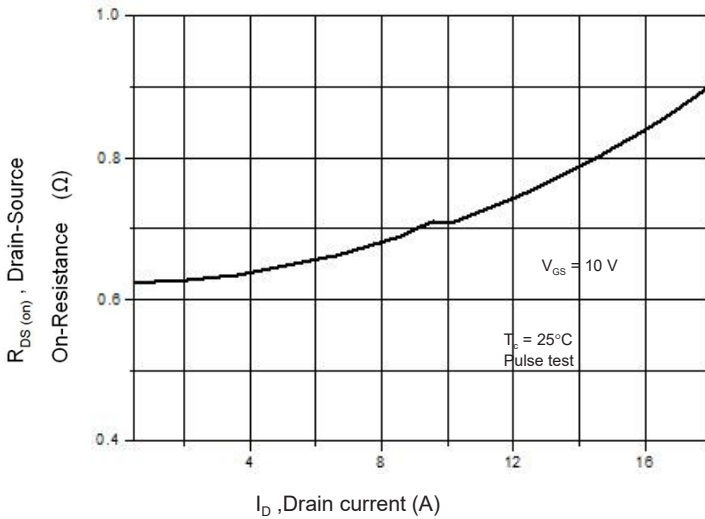

Figure 4. Threshold Voltage vs. Temperature

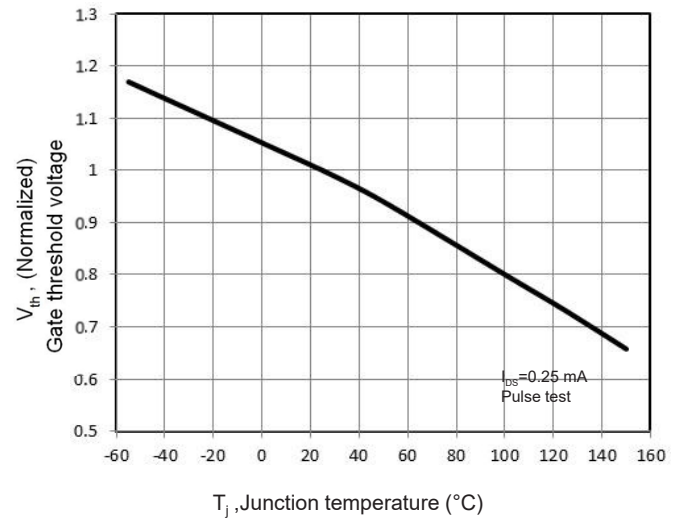

Figure 5. Breakdown Voltage vs. Temperature

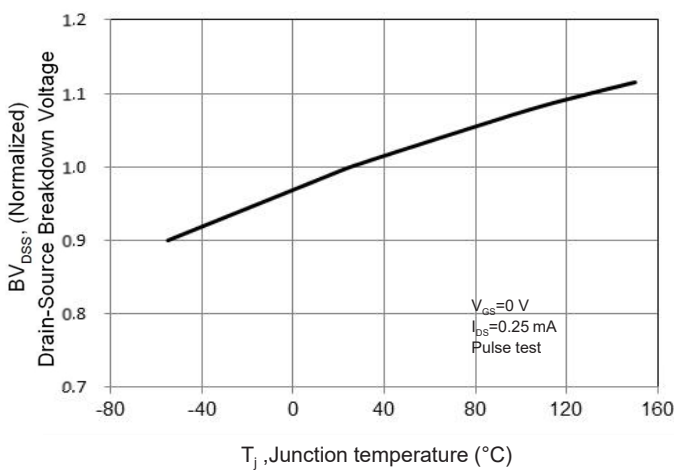

Figure 6. On-Resistance vs. Temperature

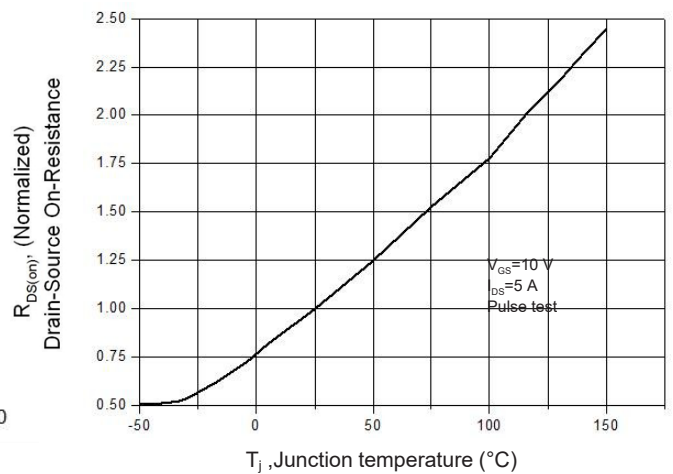

Figure 7. Capacitance Characteristics

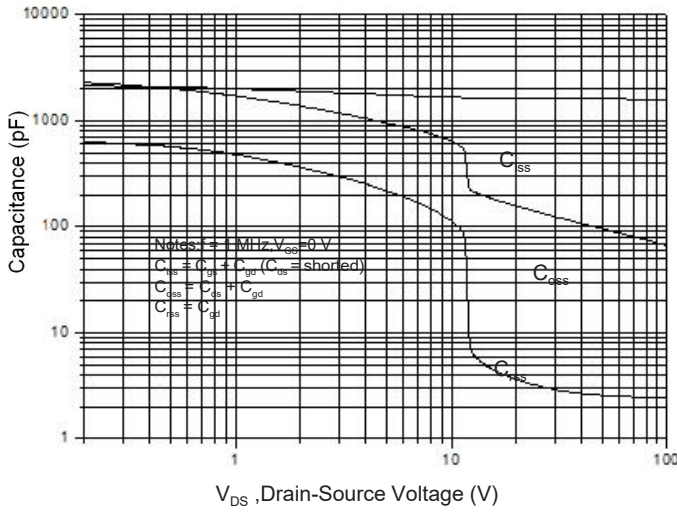

Figure 8. Gate Charge Characteristics

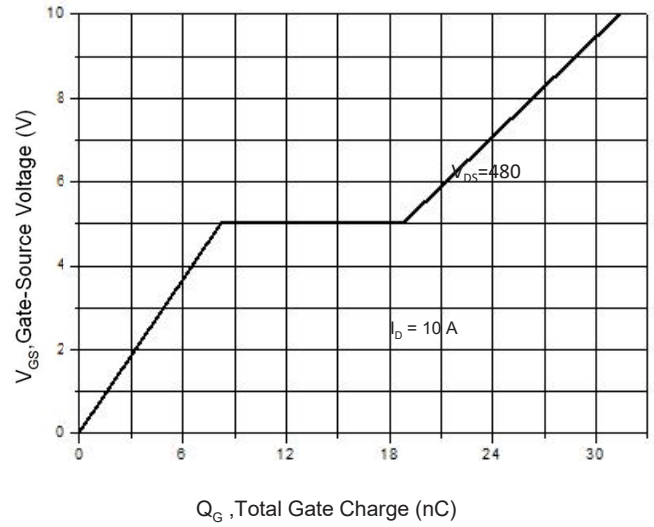

Figure 9. Maximum Safe Operating Area  
C C TO-220F

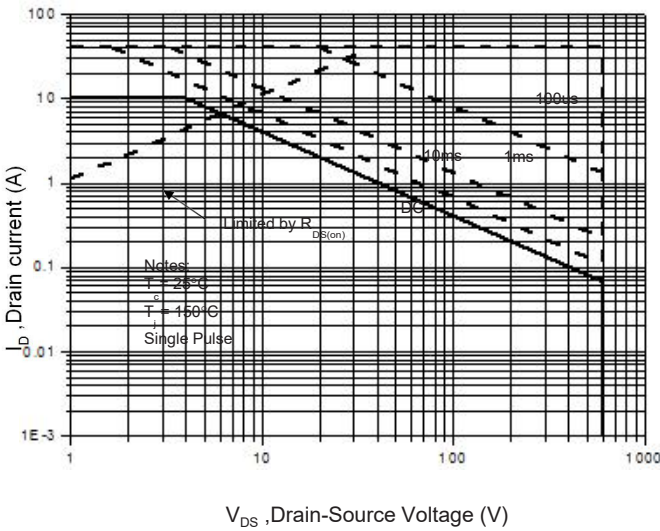

Figure 10. Maximum Safe Operating Area  
C C TO-220/O-262/TO-263

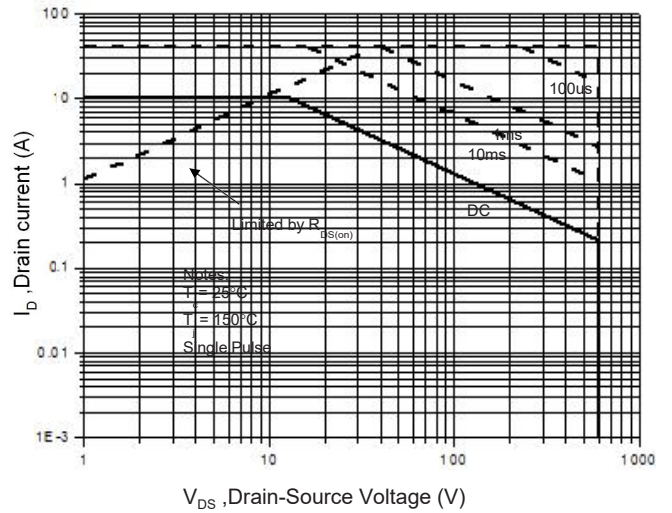

Figure 11. Power Dissipation vs. Temperature  
C C TO-220F

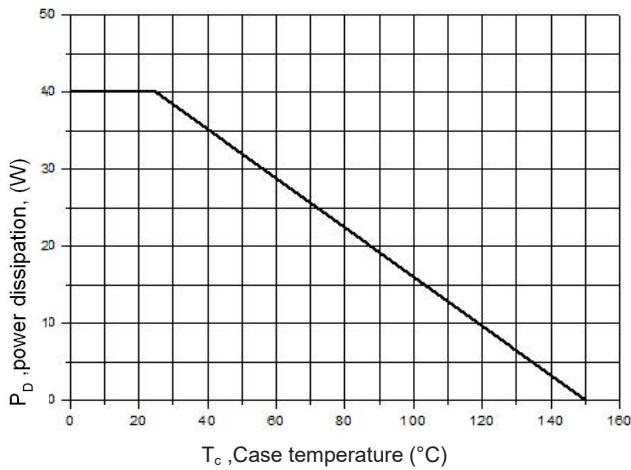

Figure 12. Power Dissipation vs. Temperature  
C C TO-220/O-262/TO-263

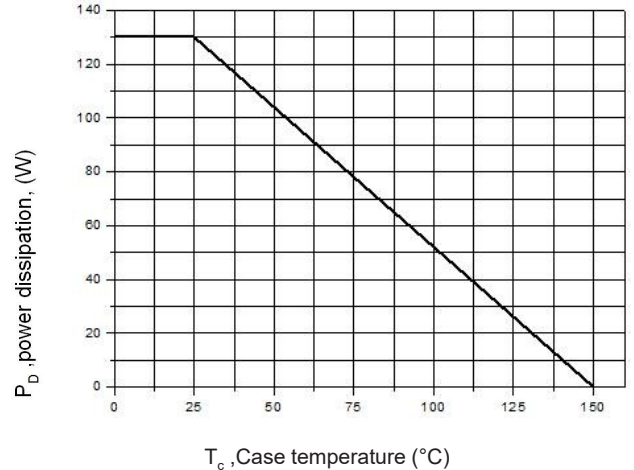

Figure 13. Continuous Drain Current vs. Temperature

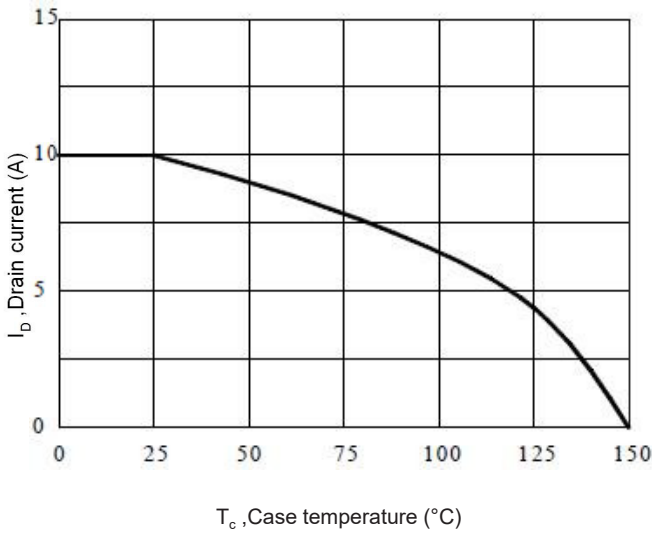
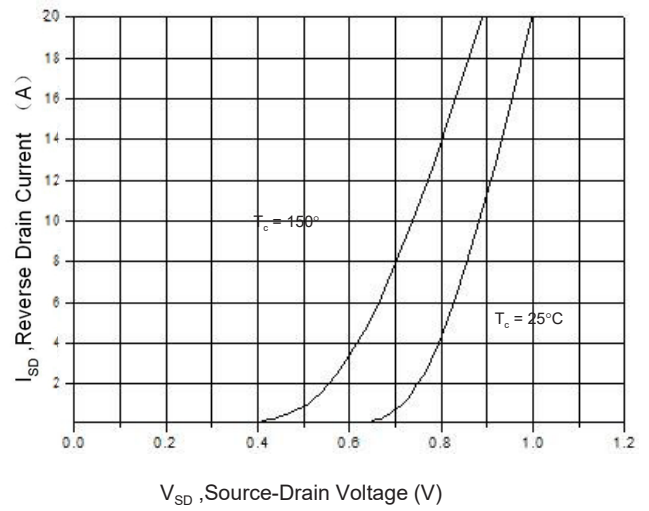
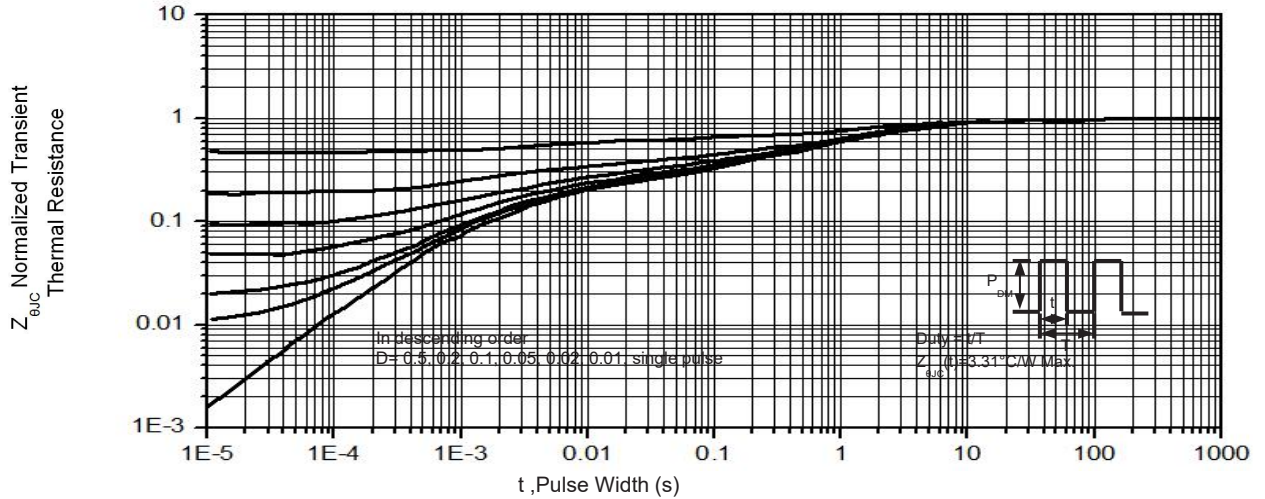
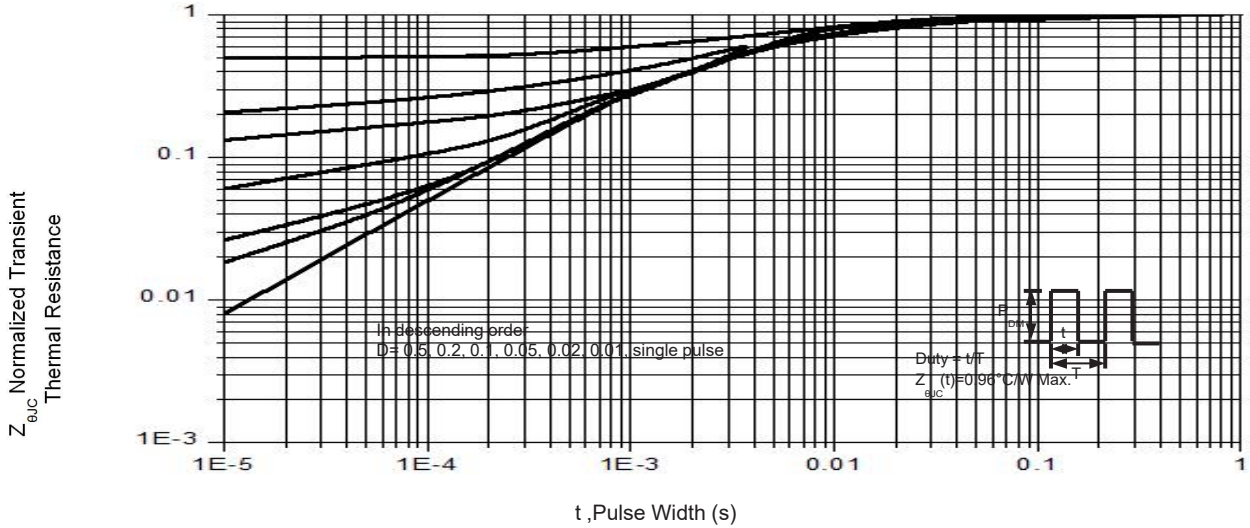
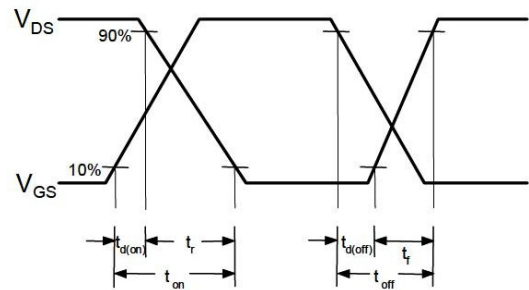
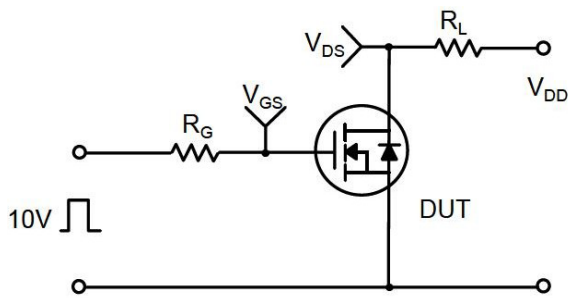
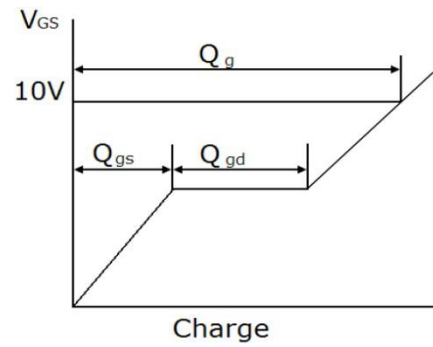
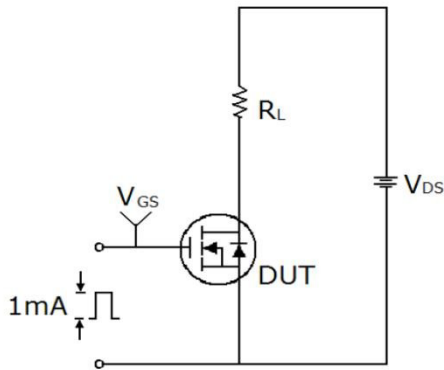

Figure 14. Body Diode Transfer Characteristics

 Figure 15 Transient Thermal Impedance, Junction to Case  $\zeta$  TO-220F

 Figure 16. Transient Thermal Impedance, Junction to Case  $\zeta$  TO-220/TO-262/TO-263

**Gate Charge Test Circuit & Waveform**

**Unclamped Inductive Switching Test Circuit & Waveforms**
