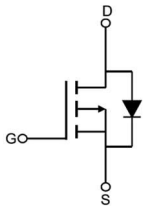

## Description

<b>Features</b> <ul style="list-style-type: none"> <li>● <math>V_{DS} = -30V</math>, <math>I_D = -10A</math></li> <li>    <math>R_{DS(ON)} &lt; 23m\Omega</math> @ <math>V_{GS} = -10V</math></li> <li>    <math>R_{DS(ON)} &lt; 34m\Omega</math> @ <math>V_{GS} = -4.5V</math></li> <li>● Advanced Trench Technology</li> <li>● Excellent <math>R_{DS(ON)}</math> and Low Gate Charge</li> <li>● Lead free product is acquired</li> </ul>	<b>Application</b> <ul style="list-style-type: none"> <li>● PWM Applications</li> <li>● Load Switch</li> <li>● Power Management</li> </ul> <p style="text-align: center;">100% UIS 100% <math>\Delta V_{ds}</math></p>
 <p>SOP-8</p>	 <p>Schematic Diagram</p>

## Package Marking and Ordering Information

Device Marking	Device	OUTLINE	Device Package	Reel Size	Reel (PCS)	Per Carton (PCS)
VSM10P03-S8	VSM10P03	TAPING	SOP-8	13inch	4000	48000

## Absolute Maximum Ratings ( $T_A = 25^\circ C$ unless otherwise specified)

Symbol	Parameter	Max.	Units
$V_{DSS}$	Drain-Source Voltage	-30	V
$V_{GSS}$	Gate-Source Voltage	$\pm 20$	V
$I_D$	Continuous Drain Current	$T_C = 25^\circ C$	-10
		$T_C = 100^\circ C$	-7
$I_{DM}$	Pulsed Drain Current <sup>note1</sup>	-40	A
$P_D$	Power Dissipation	$T_A = 25^\circ C$	3.7
$R_{\theta JA}$	Thermal Resistance, Junction to Ambient	33.8	$^\circ C/W$
$T_J, T_{STG}$	Operating and Storage Temperature Range	-55 to +150	$^\circ C$

**Electrical Characteristics** ( $T_J=25^{\circ}\text{C}$  unless otherwise specified)

Symbol	Parameter	Test Condition	Min.	Typ.	Max.	Units
<b>Off Characteristic</b>						
$V_{(BR)DSS}$	Drain-Source Breakdown Voltage	$V_{GS}=0V, I_D = -250\mu A$	-30	-	-	V
$I_{DSS}$	Zero Gate Voltage Drain Current	$V_{DS} = -30V, V_{GS} = 0V,$	-	-	-1	$\mu A$
$I_{GSS}$	Gate to Body Leakage Current	$V_{DS} = 0V, V_{GS} = \pm 20V$	-	-	$\pm 100$	nA
<b>On Characteristics</b>						
$V_{GS(th)}$	Gate Threshold Voltage	$V_{DS} = V_{GS}, I_D = -250\mu A$	-1.0	-1.5	-2.4	V
$R_{DS(on)}$	Static Drain-Source on-Resistance <small>note2</small>	$V_{GS} = -10V, I_D = -10A$	-	16	23	m $\Omega$
		$V_{GS} = -4.5V, I_D = -5A$	-	25	34	
<b>Dynamic Characteristics</b>						
$C_{iss}$	Input Capacitance	$V_{DS} = -15V, V_{GS} = 0V,$ $f = 1.0MHz$	-	1550	-	pF
$C_{oss}$	Output Capacitance		-	327	-	pF
$C_{rss}$	Reverse Transfer Capacitance		-	278	-	pF
$Q_g$	Total Gate Charge	$V_{DS} = -15V, I_D = -9.1A,$ $V_{GS} = -10V$	-	30	-	nC
$Q_{gs}$	Gate-Source Charge		-	5.3	-	nC
$Q_{gd}$	Gate-Drain("Miller") Charge		-	7.6	-	nC
<b>Switching Characteristics</b>						
$t_{d(on)}$	Turn-on Delay Time	$V_{DD} = -15V, I_D = -6A,$ $V_{GS} = -10V, R_{GEN} = 2.5\Omega$	-	14	-	ns
$t_r$	Turn-on Rise Time		-	20	-	ns
$t_{d(off)}$	Turn-off Delay Time		-	95	-	ns
$t_f$	Turn-off Fall Time		-	65	-	ns
<b>Drain-Source Diode Characteristics and Maximum Ratings</b>						
$I_S$	Maximum Continuous Drain to Source Diode Forward Current		-	-	-10	A
$I_{SM}$	Maximum Pulsed Drain to Source Diode Forward Current		-	-	-40	A
$V_{SD}$	Drain to Source Diode Forward Voltage	$V_{GS} = 0V, I_S = -10A$	-	-0.8	-1.2	V

Notes: 1. Repetitive Rating: Pulse Width Limited by Maximum Junction Temperature

 2. Pulse Test: Pulse Width  $\leq 300\mu s$ , Duty Cycle  $\leq 2\%$

## Typical Performance Characteristics

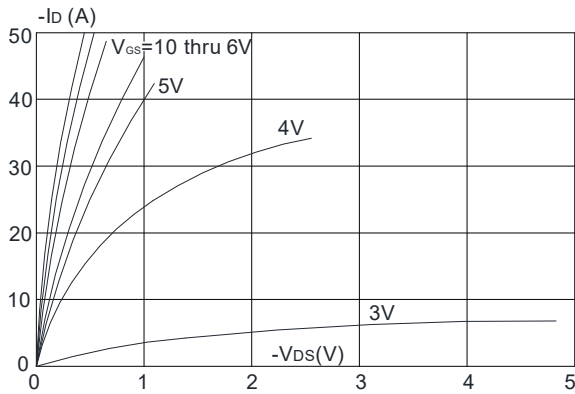
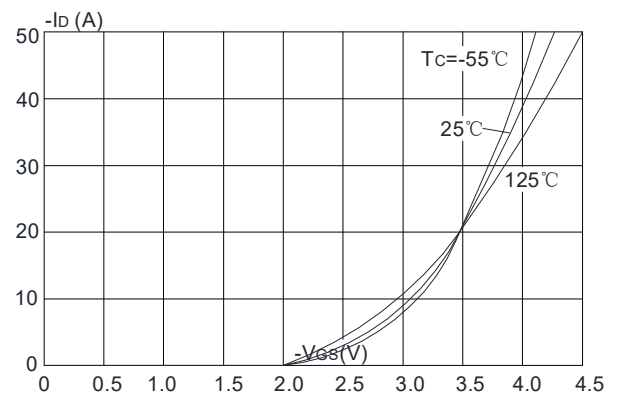
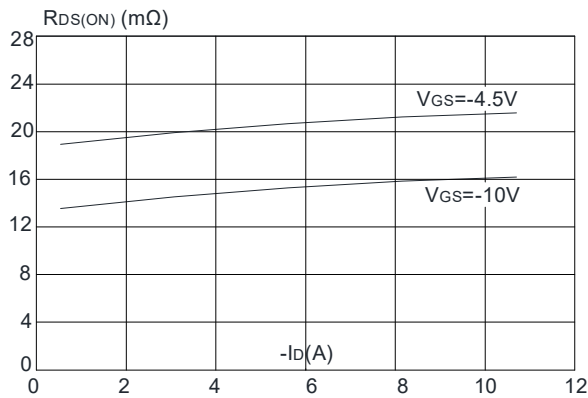
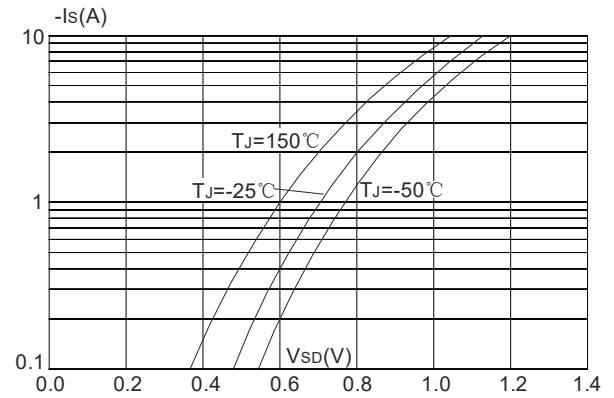
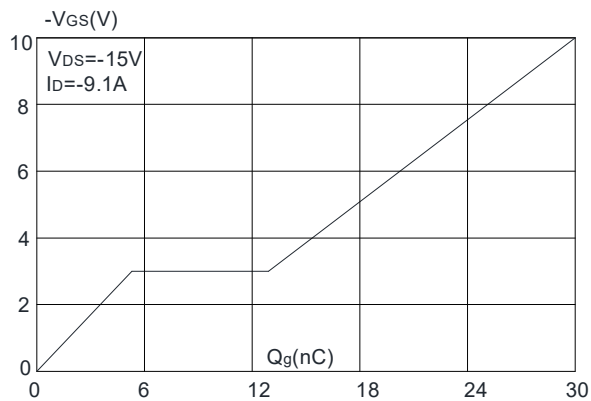
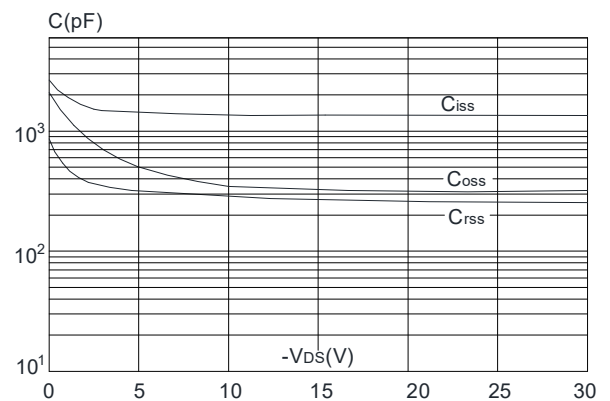
**Figure 1: Output Characteristics**

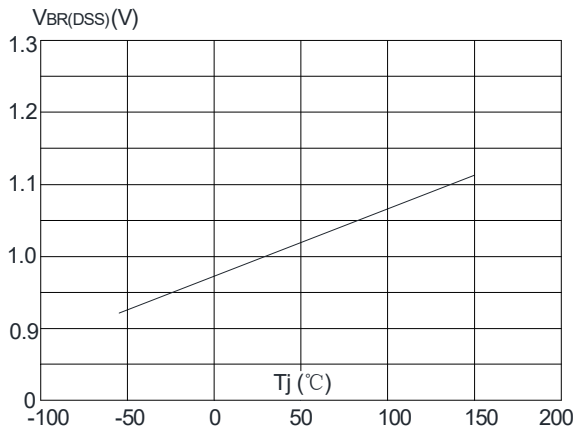
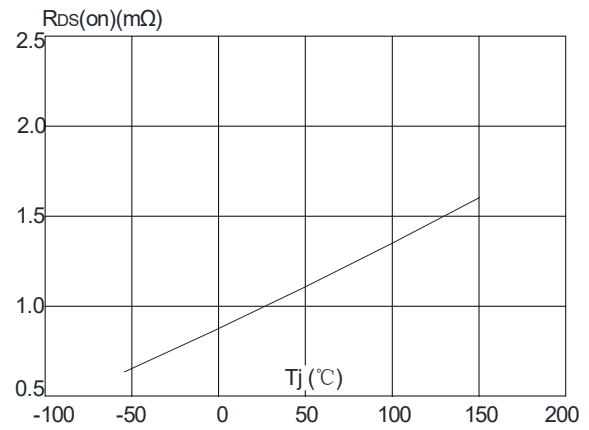
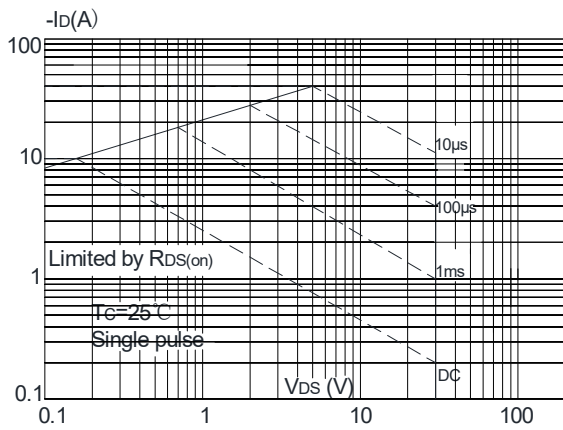
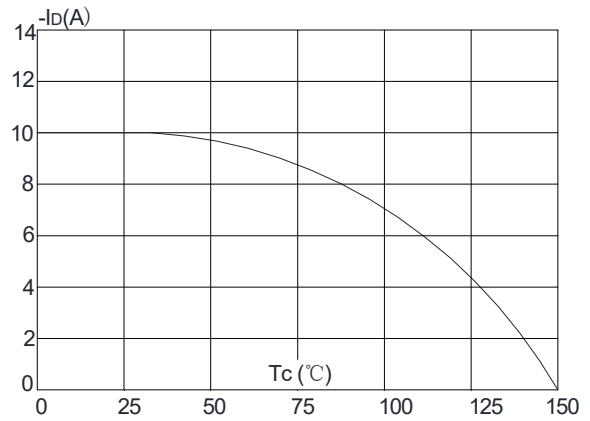
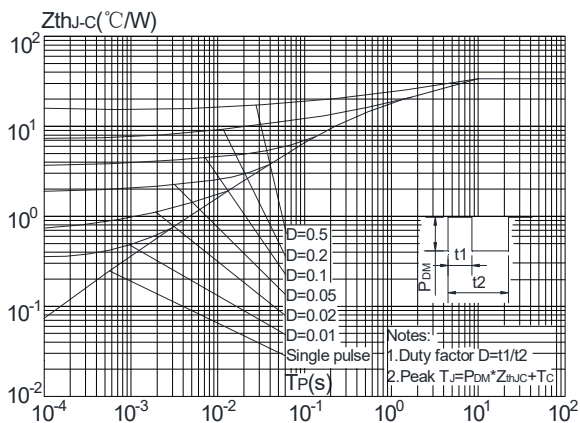
**Figure 2: Typical Transfer Characteristics**

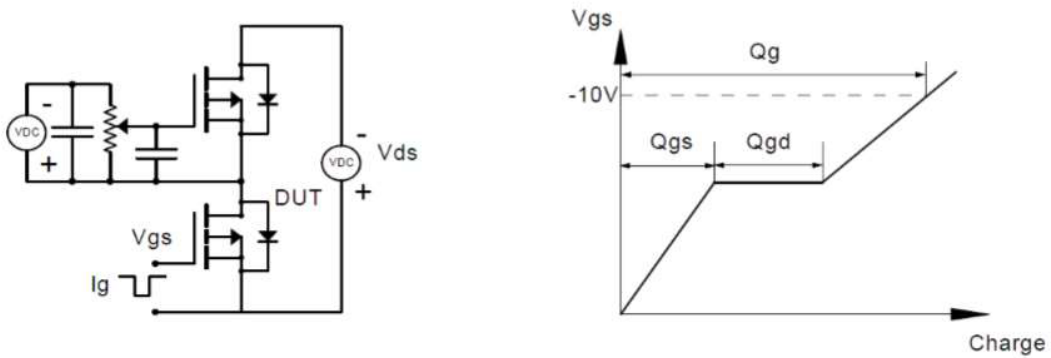
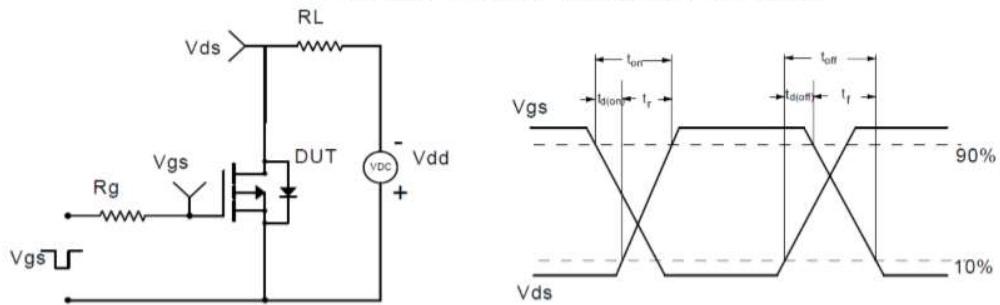
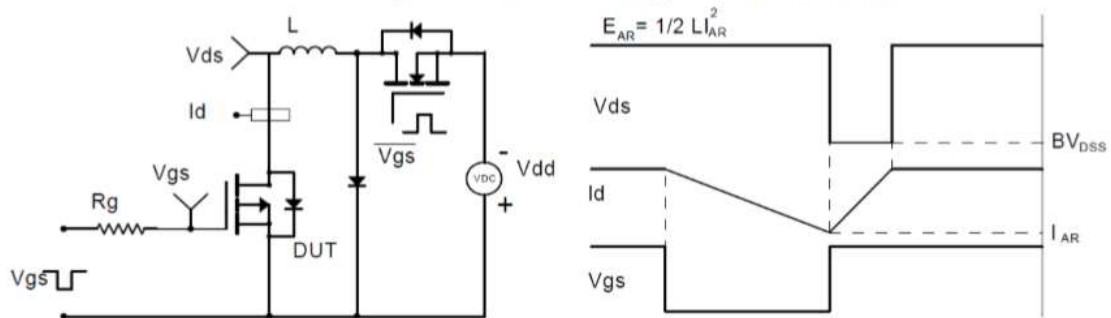
**Figure 3: On-resistance vs. Drain Current**

**Figure 4: Body Diode Characteristics**

**Figure 5: Gate Charge Characteristics**

**Figure 6: Capacitance Characteristics**

**Figure 7: Normalized Breakdown Voltage vs. Junction Temperature**

**Figure 8: Normalized on Resistance vs. Junction Temperature**

**Figure 9: Maximum Safe Operating Area**

**Figure 10: Maximum Continuous Drain Current vs. Case Temperature**

**Figure.11: Maximum Effective Transient Thermal Impedance, Junction-to-Ambient**

**Gate Charge Test Circuit & Waveform**

**Resistive Switching Test Circuit & Waveforms**

**Unclamped Inductive Switching (UIS) Test Circuit & Waveforms**

**Diode Recovery Test Circuit & Waveforms**
