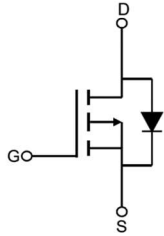

Description

Features <ul style="list-style-type: none"> ● $V_{DS} = -60V$, $I_D = -30A$ $R_{DS(ON)} < 30m\Omega$ @ $V_{GS} = -10V$ $R_{DS(ON)} < 38m\Omega$ @ $V_{GS} = -4.5V$ ● Advanced Trench Technology ● Excellent $R_{DS(ON)}$ and Low Gate Charge ● Lead free product is acquired 	Application <ul style="list-style-type: none"> ● PWM Applications ● Load Switch ● Power Management <p style="text-align: center;">100% UIS 100% ΔV_{ds}</p>
 <p>TO-252</p>	 <p>Schematic Diagram</p>

Package Marking and Ordering Information

Device Marking	Device	OUTLINE	Device Package	Reel Size	Reel (PCS)	Per Carton (PCS)
VSM30P06-T2	VSM30P06	TAPING	TO-252	13inch	2500	25000

Absolute Maximum Ratings ($T_C = 25^\circ C$ unless otherwise specified)

Symbol	Parameter	Max.	Units
V_{DSS}	Drain-Source Voltage	-60	V
V_{GSS}	Gate-Source Voltage	± 20	V
I_D	Continuous Drain Current	$T_C = 25^\circ C$	-30
		$T_C = 100^\circ C$	-20
I_{DM}	Pulsed Drain Current ^{note1}	-120	A
E_{AS}	Single Pulsed Avalanche Energy ^{note2}	90	mJ
P_D	Power Dissipation	$T_C = 25^\circ C$	51
$R_{\theta JC}$	Thermal Resistance, Junction to Case	2.5	$^\circ C/W$
T_J, T_{STG}	Operating and Storage Temperature Range	-55 to +175	$^\circ C$

Electrical Characteristics ($T_J=25^{\circ}\text{C}$ unless otherwise specified)

Symbol	Parameter	Test Condition	Min.	Typ.	Max.	Units
Off Characteristic						
$V_{(BR)DSS}$	Drain-Source Breakdown Voltage	$V_{GS}=0V, I_D=-250\mu A$	-60	-	-	V
I_{DSS}	Zero Gate Voltage Drain Current	$V_{DS}=-60V, V_{GS}=0V,$	-	-	-1	μA
I_{GSS}	Gate to Body Leakage Current	$V_{DS}=0V, V_{GS}=\pm 20V$	-	-	± 100	nA
On Characteristics						
$V_{GS(th)}$	Gate Threshold Voltage	$V_{DS}=V_{GS}, I_D=-250\mu A$	-1.0	-1.7	-2.5	V
$R_{DS(on)}$	Static Drain-Source on-Resistance <small>note3</small>	$V_{GS}=-10V, I_D=-15A$	-	23	30	m Ω
		$V_{GS}=-4.5V, I_D=-10A$	-	27	38	
Dynamic Characteristics						
C_{iss}	Input Capacitance	$V_{DS}=-25V, V_{GS}=0V,$ $f=1.0MHz$	-	2400	-	pF
C_{oss}	Output Capacitance		-	251	-	pF
C_{rss}	Reverse Transfer Capacitance		-	196	-	pF
Q_g	Total Gate Charge	$V_{DS}=-30V, I_D=-15A,$ $V_{GS}=-10V$	-	49	-	nC
Q_{gs}	Gate-Source Charge		-	8	-	nC
Q_{gd}	Gate-Drain("Miller") Charge		-	12	-	nC
Switching Characteristics						
$t_{d(on)}$	Turn-on Delay Time	$V_{DD}=-30V, I_D=-30A,$ $V_{GS}=-10V, R_{GEN}=2.5\Omega$	-	15	-	ns
t_r	Turn-on Rise Time		-	120	-	ns
$t_{d(off)}$	Turn-off Delay Time		-	245	-	ns
t_f	Turn-off Fall Time		-	199	-	ns
Drain-Source Diode Characteristics and Maximum Ratings						
I_S	Maximum Continuous Drain to Source Diode Forward Current		-	-	-30	A
I_{SM}	Maximum Pulsed Drain to Source Diode Forward Current		-	-	-120	A
V_{SD}	Drain to Source Diode Forward Voltage	$V_{GS}=0V, I_S=-30A$	-	-0.8	-1.2	V

Notes:1. Repetitive Rating: Pulse Width Limited by Maximum Junction Temperature

 2. E_{AS} condition: $T_J=25^{\circ}\text{C}, V_{DD}=-50V, V_G=-10V, R_G=25\Omega, L=0.5mH, I_{AS}=-19A$

 3. Pulse Test: Pulse Width $\leq 300\mu s$, Duty Cycle $\leq 2\%$

Typical Performance Characteristics

Figure 1: Output Characteristics

Figure 2: Typical Transfer Characteristics

Figure 3: On-resistance vs. Drain Current

Figure 4: Body Diode Characteristics

Figure 5: Gate Charge Characteristics

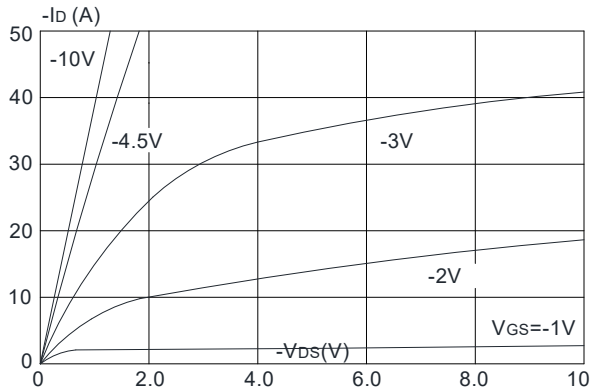
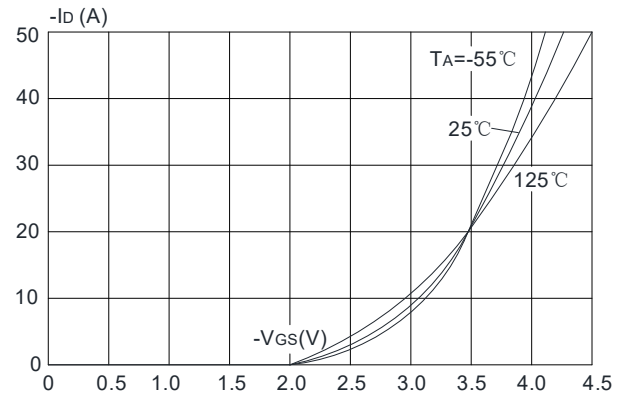
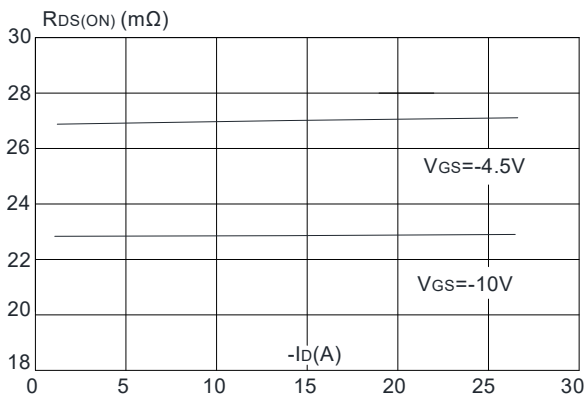
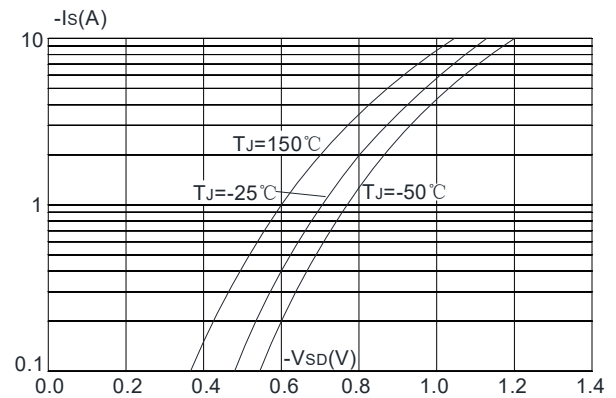
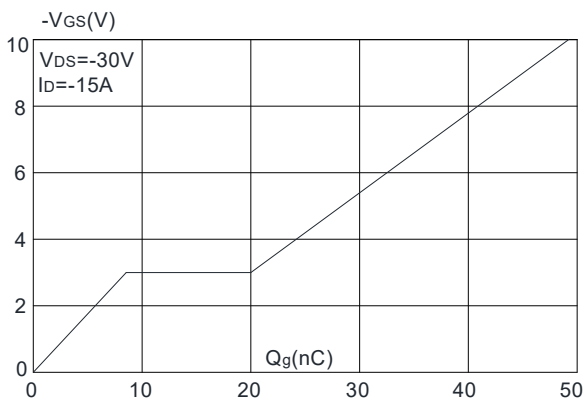
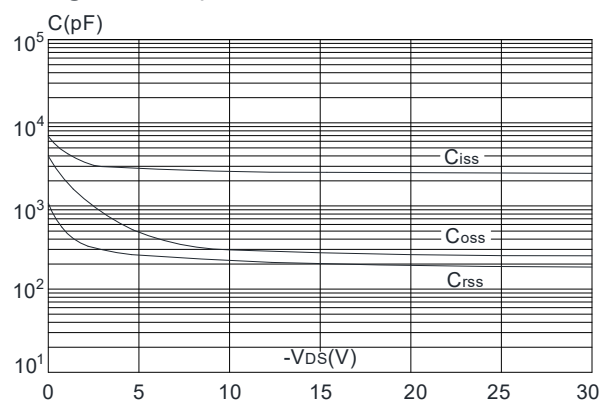
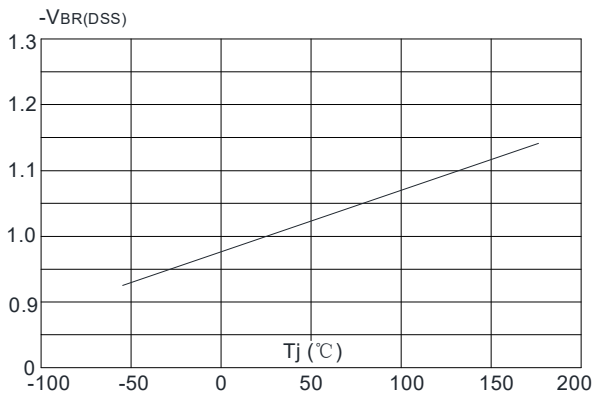
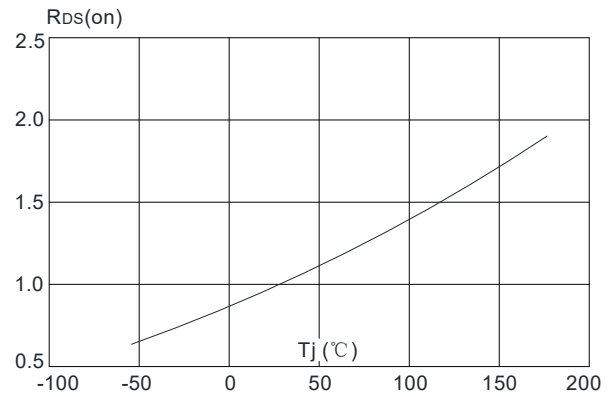
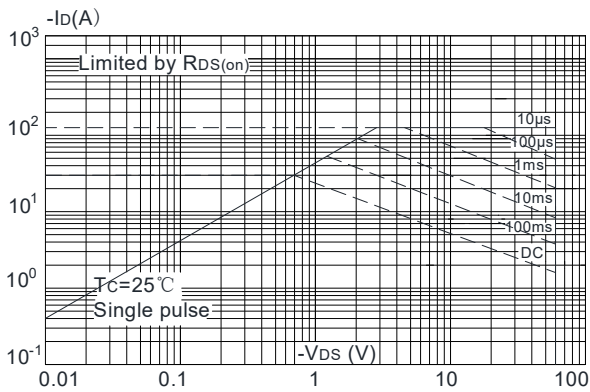
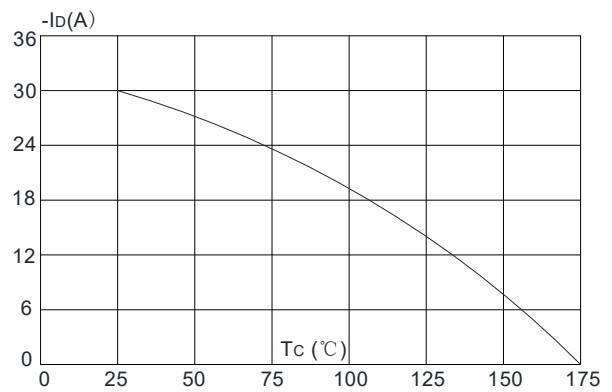
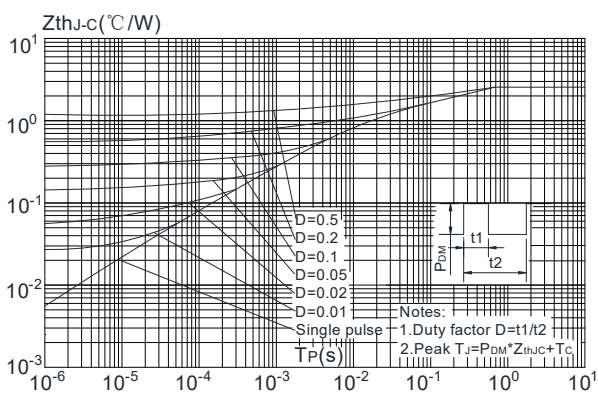
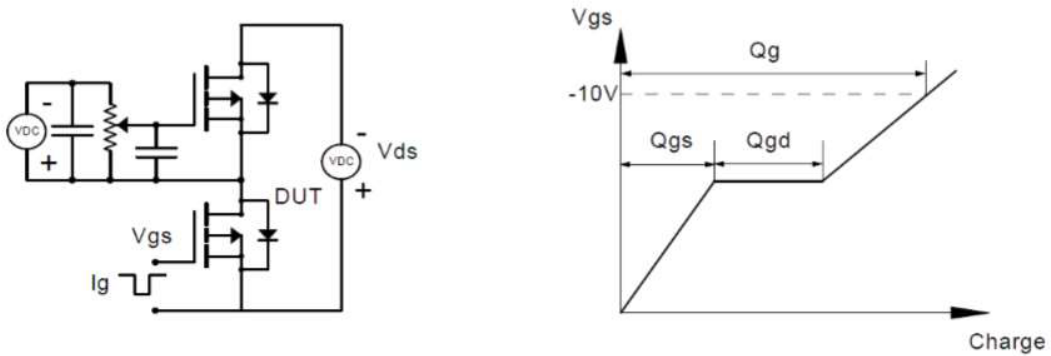
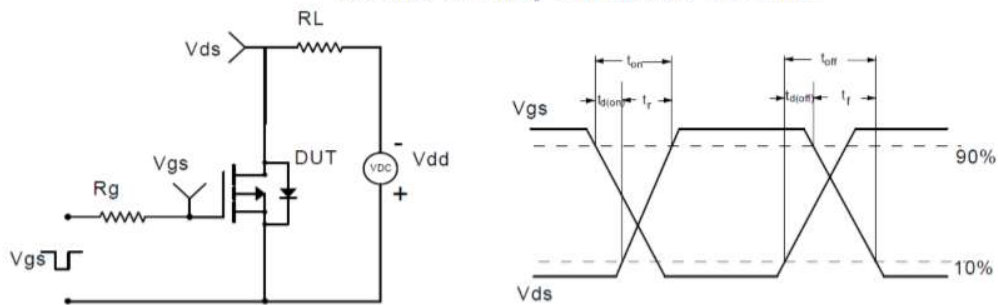
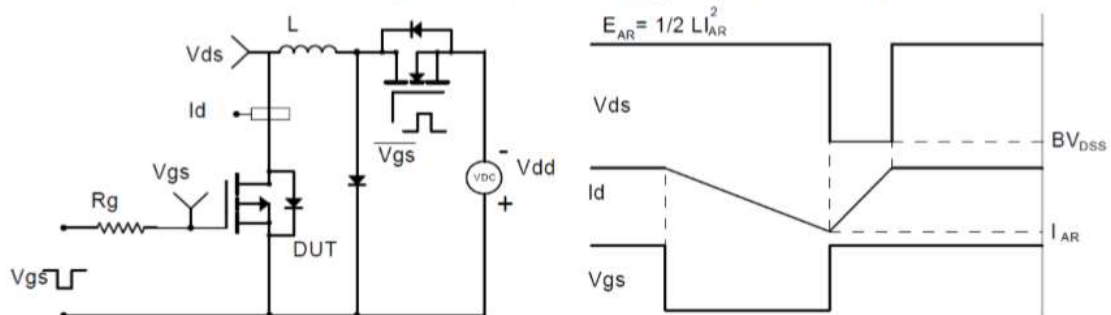
Figure 6: Capacitance Characteristics

Figure 7: Normalized Breakdown Voltage vs. Junction Temperature

Figure 8: Normalized on Resistance vs. Junction Temperature

Figure 9: Maximum Safe Operating Area

Figure 10: Maximum Continuous Drain Current vs. Case Temperature

Figure.11: Maximum Effective Transient Thermal Impedance, Junction-to-Case

Test Circuit

Gate Charge Test Circuit & Waveform

Resistive Switching Test Circuit & Waveforms

Unclamped Inductive Switching (UIS) Test Circuit & Waveforms

Diode Recovery Test Circuit & Waveforms
