
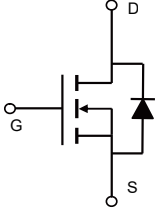


<p>Description</p> <p>These N-Channel enhancement mode power field effect transistors are using split gate trench DMOS technology. This advanced technology has been especially tailored to minimize on-state resistance, provide superior switching performance, and with stand high energy pulse in the avalanche and commutation mode. These devices are well suited for high efficiency fast switching applications.</p> <p>Features</p> <ul style="list-style-type: none"> ◆ 40V,141A, $R_{DS(on),max} = 2.8m\Omega @ V_{GS} = 10V$ ◆ Improved dv/dt capability ◆ Fast switching ◆ 100% EAS Guaranteed ◆ Green device available <p>Applications</p> <ul style="list-style-type: none"> ◆ Motor Drives ◆ UPS ◆ DC-DC Converter 	<p>Product Summary</p> <table> <tr> <td>V_{DSS}</td> <td>40V</td> </tr> <tr> <td>$R_{DS(on),max} @ V_{GS}=10V$</td> <td>2.8m$\Omega$</td> </tr> <tr> <td>$I_D$</td> <td>141A</td> </tr> </table> <p>Pin Configuration</p> <div style="display: flex; justify-content: space-around; align-items: center;"> <div style="text-align: center;">  <p>TO-263</p> </div> <div style="text-align: center;">  <p>Schematic</p> </div> </div>	V_{DSS}	40V	$R_{DS(on),max} @ V_{GS}=10V$	2.8m Ω	I_D	141A
V_{DSS}	40V						
$R_{DS(on),max} @ V_{GS}=10V$	2.8m Ω						
I_D	141A						

Absolute Maximum Ratings $T_C = 25^\circ C$ unless otherwise noted

Parameter	Symbol	Value	Unit
Drain-Source Voltage	V_{DSS}	40	V
Continuous drain current ($T_C = 25^\circ C$)	I_D	141	A
		($T_C = 100^\circ C$)	89
Pulsed drain current ¹⁾	I_{DM}	423	A
Gate-Source voltage	V_{GSS}	± 20	V
Avalanche energy ²⁾	E_{AS}	36	mJ
Power Dissipation	P_D	89	W
Storage Temperature Range	T_{STG}	-55 to +150	$^\circ C$
Operating Junction Temperature Range	T_J	-55 to +150	$^\circ C$

Thermal Characteristics

Parameter	Symbol	Value	Unit
Thermal Resistance, Junction-to-Case	$R_{\theta JC}$	1.4	$^\circ C/W$
Thermal Resistance Junction-to-Ambient	$R_{\theta JA}$	50	$^\circ C/W$

Package Marking and Ordering Information

Device	Device Package	Marking	Units/Reel
VST04N028-T3	TO-263	VST04N028-T3	800

Electrical Characteristics
 $T_J = 25^\circ\text{C}$ unless otherwise noted

Parameter	Symbol	Test Condition	Min.	Typ.	Max.	Unit
Static characteristics						
Drain-source breakdown voltage	BV_{DSS}	$V_{GS}=0\text{ V}, I_D=250\mu\text{A}$	40	---	---	V
Gate threshold voltage	$V_{GS(th)}$	$V_{DS}=V_{GS}, I_D=250\mu\text{A}$	1.2	1.7	2.5	V
Drain-source leakage current	I_{DSS}	$V_{DS}=40\text{ V}, V_{GS}=0\text{V}$	---	---	1	μA
Gate leakage current, Forward	I_{GSSF}	$V_{GS}=20\text{ V}, V_{DS}=0\text{ V}$	---	---	100	nA
Gate leakage current, Reverse	I_{GSSR}	$V_{GS}=-20\text{ V}, V_{DS}=0\text{ V}$	---	---	-100	nA
Drain-source on-state resistance	$R_{DS(on)}$	$V_{GS}=10\text{ V}, I_D=20\text{ A}$	---	2.2	2.8	$\text{m}\Omega$
		$V_{GS}=4.5\text{ V}, I_D=20\text{ A}$	---	2.8	3.8	$\text{m}\Omega$
Forward transconductance	g_{fs}	$V_{DS}=5\text{ V}, I_D=20\text{A}$	---	55	---	S
Dynamic characteristics						
Input capacitance	C_{iss}	$V_{DS}=20\text{ V}, V_{GS}=0\text{ V},$ $F=1\text{MHz}$	---	3975	---	pF
Output capacitance	C_{oss}		---	1123	---	
Reverse transfer capacitance	C_{rss}		---	84	---	
Turn-on delay time	$t_{d(on)}$	$V_{DD}=15\text{V}, V_{GS}=10\text{V}, I_D=20\text{A}$ $R_G=3.3\Omega$	---	18.7	---	ns
Rise time	t_r		---	9.3	---	
Turn-off delay time	$t_{d(off)}$		---	58.1	---	
Fall time	t_f		---	32.5	---	
Gate resistance	R_g	$V_{GS}=0\text{ V}, V_{DS}=0\text{ V}, F=1\text{MHz}$	---	1.1	---	Ω
Gate charge characteristics						
Gate to source charge	Q_{gs}	$V_{DS}=15\text{V}, I_D=20\text{A},$ $V_{GS}=10\text{ V}$	---	12.3	---	nC
Gate to drain charge	Q_{gd}		---	18.2	---	
Gate charge total	Q_g		---	56	---	
Drain-Source diode characteristics and Maximum Ratings						
Continuous Source Current	I_S		---	---	74	A
Pulsed Source Current ³⁾	I_{SM}		---	---	222	A
Diode Forward Voltage	V_{SD}	$V_{GS}=0\text{V}, I_S=20\text{A}, T_J=25^\circ\text{C}$	---	---	1.2	V

Notes:

1: Repetitive Rating: Pulse width limited by maximum junction temperature.

 2: $V_{DD}=25\text{V}, V_{GS}=10\text{V}, L=0.1\text{mH}, I_{AS}=27\text{A}$, Starting $T_J=25^\circ\text{C}$.

 3: Pulse Test: Pulse Width $\leq 300\mu\text{s}$, Duty Cycle $\leq 2\%$.

Electrical Characteristics Diagrams

Figure 1. Typ. Output Characteristics

Figure 2. Transfer Characteristics

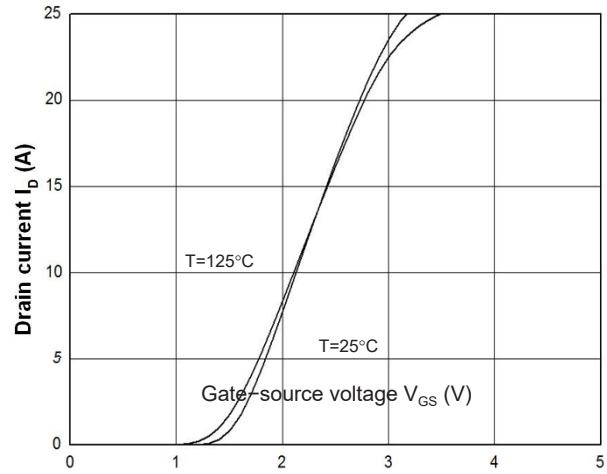


Figure 3. Capacitance Characteristics

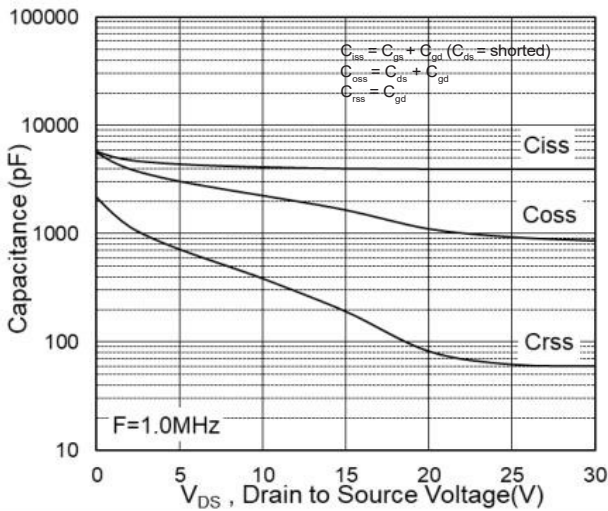


Figure 4. Gate Charge Waveform

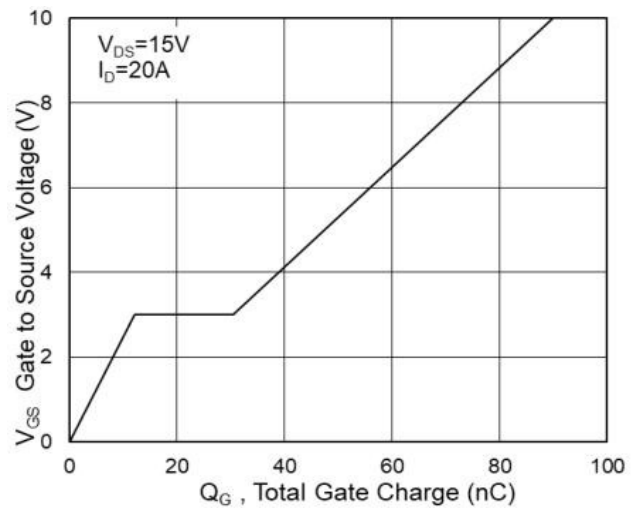


Figure 5. Body-Diode Characteristics

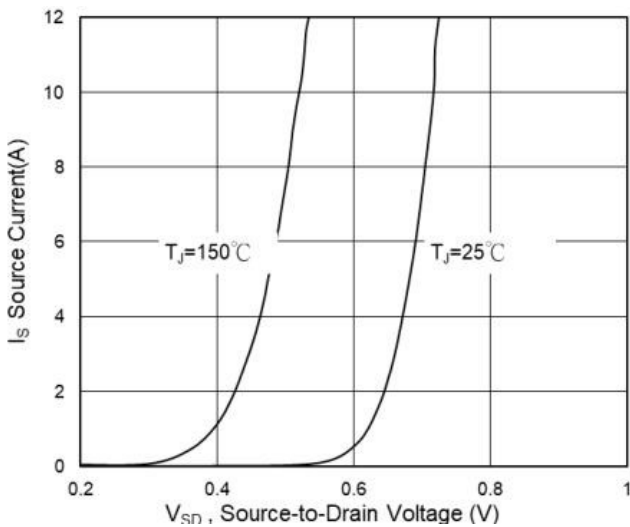


Figure 6. R_dson-Drain Current

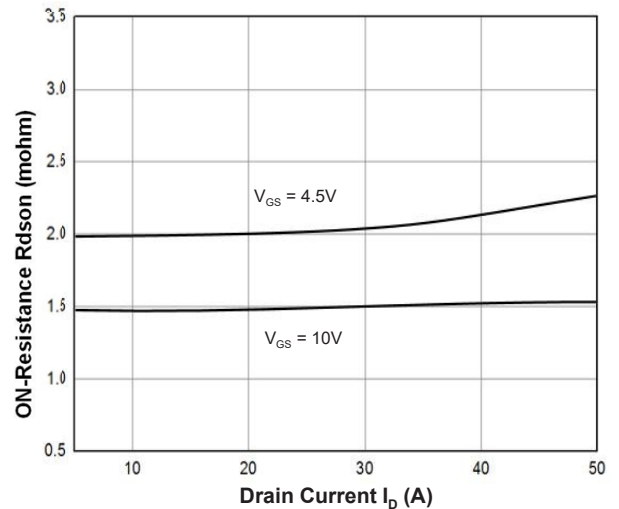


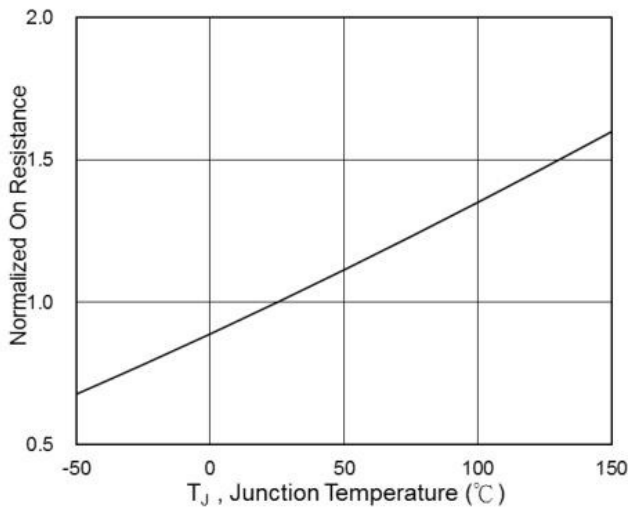
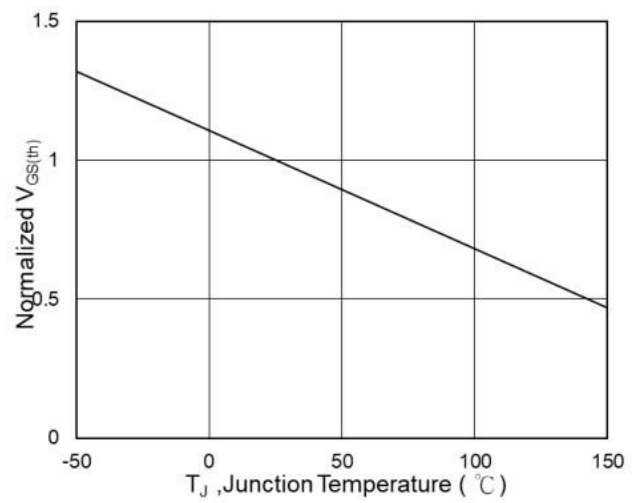
Figure 7. $R_{ds(on)}$ -Junction Temperature

 Figure 8. $V_{GS(th)}$ -Junction Temperature


Figure 9. On-Resistance vs. Gate-to-Source voltage

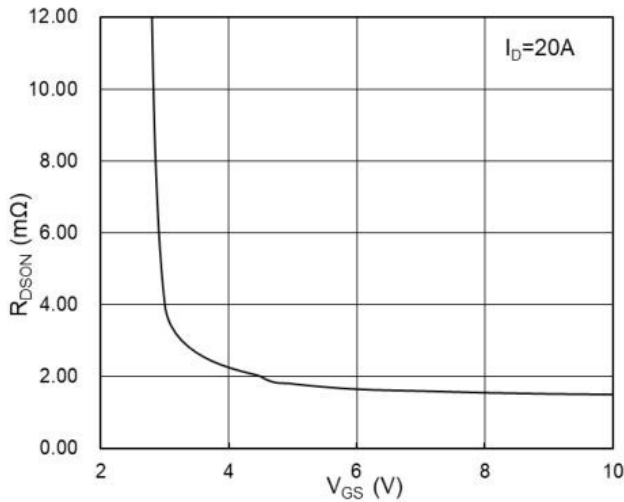
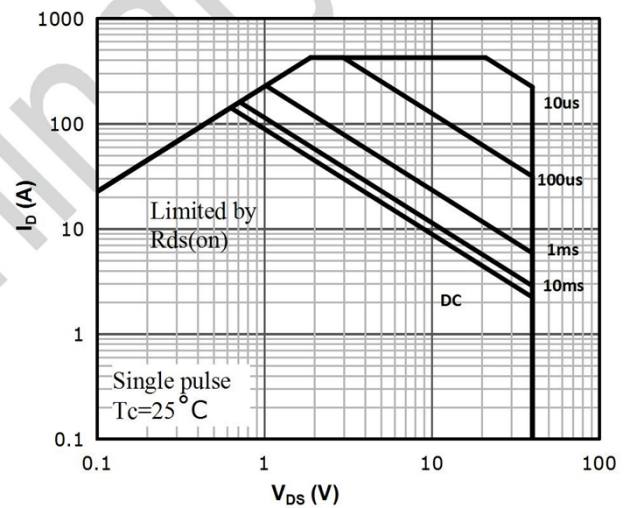
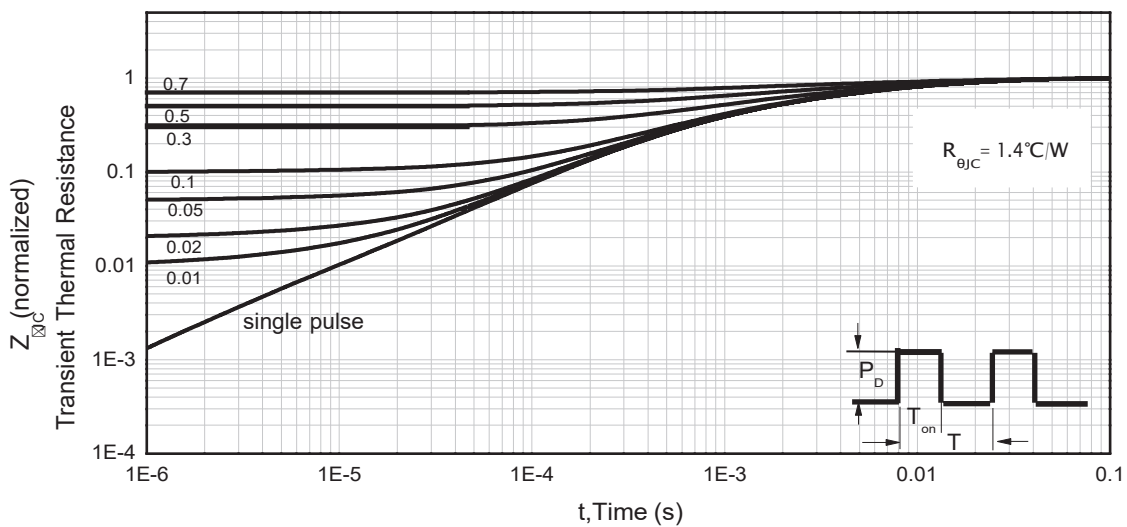
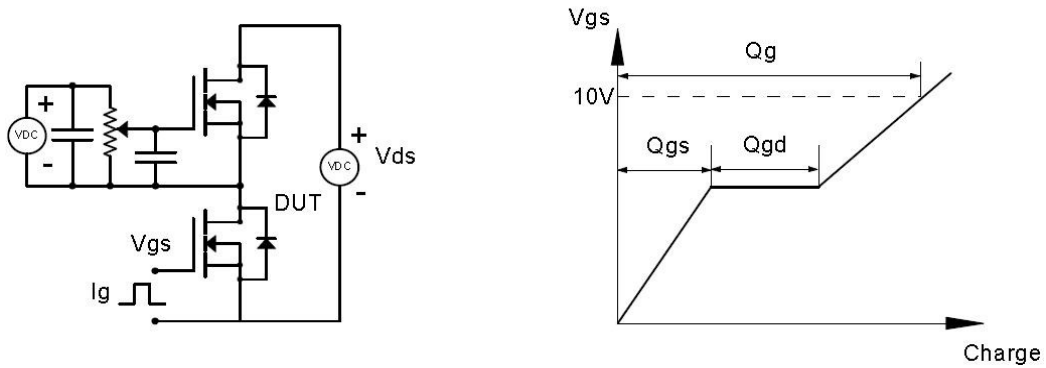


Figure 10: Safe Operating Area

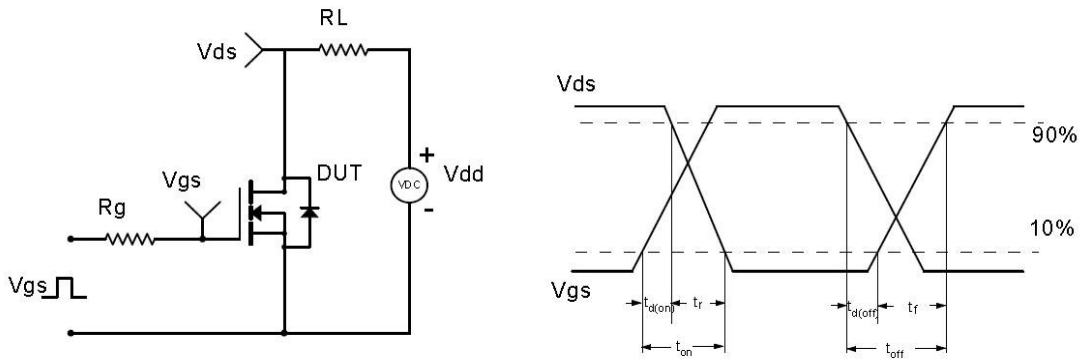

 Figure 11. Normalized Maximum Transient Thermal Impedance (R_{thJC})


Test Circuit & Waveform

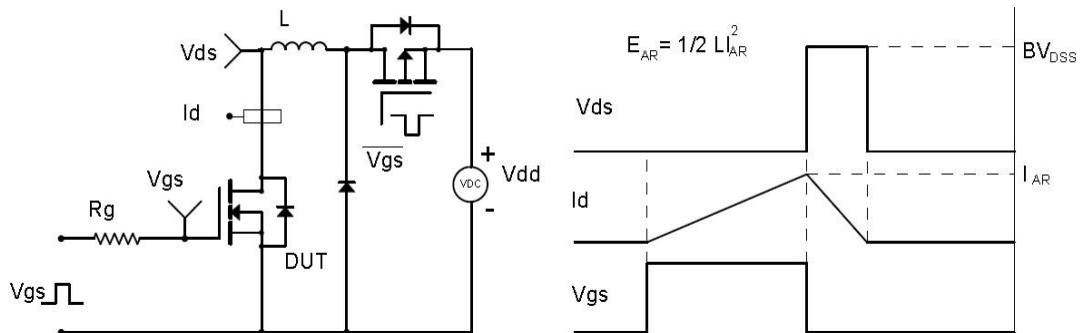
Gate Charge Test Circuit & Waveform



Resistive Switching Test Circuit & Waveforms



Unclamped Inductive Switching (UIS) Test Circuit & Waveforms



Diode Recovery Test Circuit & Waveforms

