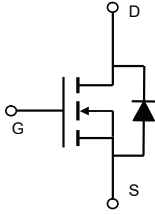

<p><b>Description</b></p> <p>These N-Channel enhancement mode power field effect transistors are using split gate trench DMOS technology. This advanced technology has been especially tailored to minimize on-state resistance, provide superior switching performance, and with stand high energy pulse in the avalanche and commutation mode. These devices are well suited for high efficiency fast switching applications.</p> <p><b>Features</b></p> <ul style="list-style-type: none"> <li>◆ 60V, 104A, <math>R_{DS(on),max} = 4.6m\Omega @ V_{GS} = 10V</math></li> <li>◆ Improved dv/dt capability</li> <li>◆ Fast switching</li> <li>◆ 100% EAS Guaranteed</li> <li>◆ Green device available</li> </ul> <p><b>Applications</b></p> <ul style="list-style-type: none"> <li>◆ Motor Drives</li> <li>◆ UPS</li> <li>◆ DC-DC Converter</li> </ul>	<p><b>Product Summary</b></p> <table> <tr> <td><math>V_{DSS}</math></td> <td>60V</td> </tr> <tr> <td><math>R_{DS(on),max} @ V_{GS}=10V</math></td> <td>4.6m<math>\Omega</math></td> </tr> <tr> <td><math>I_D</math></td> <td>104A</td> </tr> </table> <p><b>Pin Configuration</b></p> <div style="display: flex; justify-content: space-around; align-items: center;"> <div style="text-align: center;">  <p>TO-220C</p> </div> <div style="text-align: center;">  <p>Schematic</p> </div> </div>	$V_{DSS}$	60V	$R_{DS(on),max} @ V_{GS}=10V$	4.6m $\Omega$	$I_D$	104A
$V_{DSS}$	60V						
$R_{DS(on),max} @ V_{GS}=10V$	4.6m $\Omega$						
$I_D$	104A						

**Absolute Maximum Ratings**  $T_C = 25^\circ C$  unless otherwise noted

Parameter	Symbol	Value	Unit
Drain-Source Voltage	$V_{DSS}$	60	V
Continuous drain current ( $T_C = 25^\circ C$ )	$I_D$	104	A
		( $T_C = 100^\circ C$ )	65
Pulsed drain current <sup>1)</sup>	$I_{DM}$	312	A
Gate-Source voltage	$V_{GSS}$	$\pm 20$	V
Avalanche energy <sup>2)</sup>	$E_{AS}$	28	mJ
Power Dissipation	$P_D$	89	W
Storage Temperature Range	$T_{STG}$	-55 to +150	$^\circ C$
Operating Junction Temperature Range	$T_J$	-55 to +150	$^\circ C$

**Thermal Characteristics**

Parameter	Symbol	Value	Unit
Thermal Resistance, Junction-to-Case	$R_{\theta JC}$	1.4	$^\circ C/W$
Thermal Resistance Junction-to-Ambient	$R_{\theta JA}$	55	$^\circ C/W$

**Package Marking and Ordering Information**

Device	Device Package	Marking	Units/Tube
VST06N046-TC	TO-220C	VST06N046-TC	50

**Electrical Characteristics**
 $T_J = 25^\circ\text{C}$  unless otherwise noted

Parameter	Symbol	Test Condition	Min.	Typ.	Max.	Unit
<b>Static characteristics</b>						
Drain-source breakdown voltage	$BV_{DSS}$	$V_{GS}=0\text{ V}, I_D=250\mu\text{A}$	60	---	---	V
Gate threshold voltage	$V_{GS(th)}$	$V_{DS}=V_{GS}, I_D=250\mu\text{A}$	2.0	3.0	4.0	V
Drain-source leakage current	$I_{DSS}$	$V_{DS}=60\text{ V}, V_{GS}=0\text{ V}$	---	---	1	$\mu\text{A}$
Gate leakage current, Forward	$I_{GSSF}$	$V_{GS}=20\text{ V}, V_{DS}=0\text{ V}$	---	---	100	nA
Gate leakage current, Reverse	$I_{GSSR}$	$V_{GS}=-20\text{ V}, V_{DS}=0\text{ V}$	---	---	-100	nA
Drain-source on-state resistance	$R_{DS(on)}$	$V_{GS}=10\text{ V}, I_D=20\text{ A}$	---	3.6	4.6	m $\Omega$
Forward transconductance	$g_{fs}$	$V_{DS}=5\text{ V}, I_D=20\text{ A}$	---	66	---	S
<b>Dynamic characteristics</b>						
Input capacitance	$C_{iss}$	$V_{DS}=30\text{ V}, V_{GS}=0\text{ V},$ $F=1\text{ MHz}$	---	3511	---	pF
Output capacitance	$C_{oss}$		---	1176	---	
Reverse transfer capacitance	$C_{rss}$		---	67	---	
Turn-on delay time	$t_{d(on)}$	$V_{DD}=30\text{ V}, V_{GS}=10\text{ V}, I_D=20\text{ A}$ $R_G=3\Omega$	---	20.3	---	ns
Rise time	$t_r$		---	9.6	---	
Turn-off delay time	$t_{d(off)}$		---	61	---	
Fall time	$t_f$		---	15.2	---	
Gate resistance	$R_g$	$V_{GS}=0\text{ V}, V_{DS}=0\text{ V}, F=1\text{ MHz}$	---	1.1	---	$\Omega$
<b>Gate charge characteristics</b>						
Gate to source charge	$Q_{gs}$	$V_{DS}=30\text{ V}, I_D=20\text{ A},$ $V_{GS}=10\text{ V}$	---	15.5	---	nC
Gate to drain charge	$Q_{gd}$		---	9.5	---	
Gate charge total	$Q_g$		---	48	---	
<b>Drain-Source diode characteristics and Maximum Ratings</b>						
Continuous Source Current	$I_S$		---	---	74	A
Pulsed Source Current <sup>3)</sup>	$I_{SM}$		---	---	222	A
Diode Forward Voltage	$V_{SD}$	$V_{GS}=0\text{ V}, I_S=20\text{ A}, T_J=25^\circ\text{C}$	---	---	1.2	V
Reverse recovery time	$t_{rr}$	$I_F=20\text{ A}, dI_F/dt=100\text{ A}/\mu\text{s}$	---	24	---	ns
Reverse recovery charge	$Q_{rr}$		---	85	---	nC

Notes:

1: Repetitive Rating: Pulse width limited by maximum junction temperature.

 2:  $V_{DD}=50\text{ V}, V_{GS}=10\text{ V}, L=0.1\text{ mH}, I_{AS}=24\text{ A}$ , Starting  $T_J=25^\circ\text{C}$ .

 3: Pulse Test: Pulse Width  $\leq 300\ \mu\text{s}$ , Duty Cycle  $\leq 2\%$ .

**Electrical Characteristics Diagrams**

Figure 1. Typ. Output Characteristics

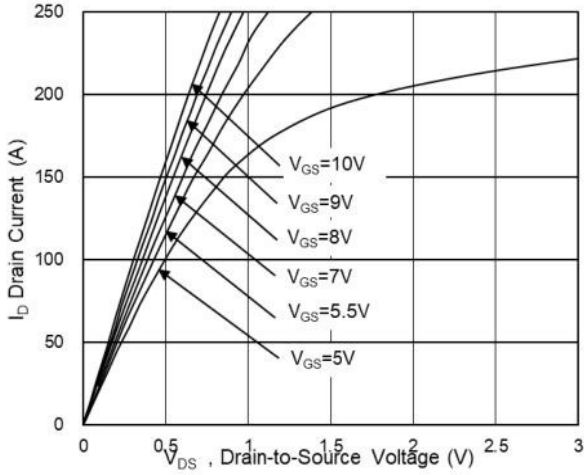

Figure 2. Transfer Characteristics

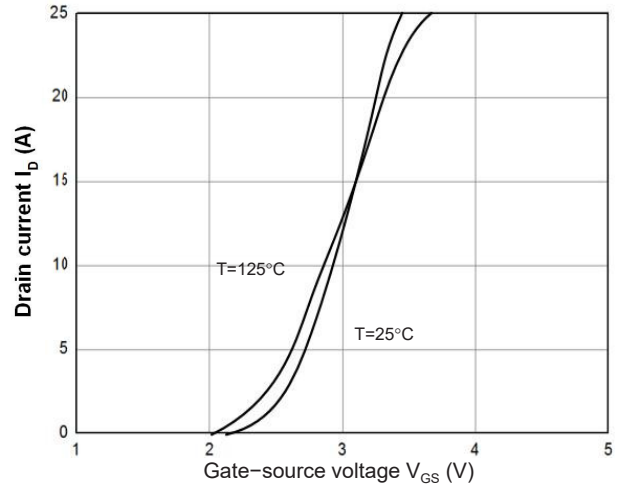

Figure 3. Capacitance Characteristics

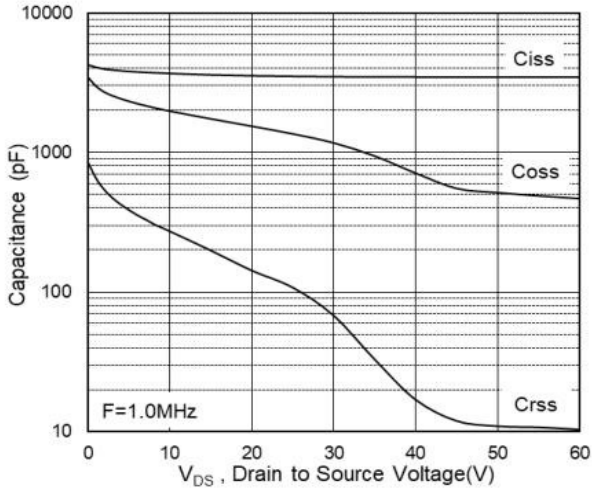

Figure 4. Gate Charge Waveform

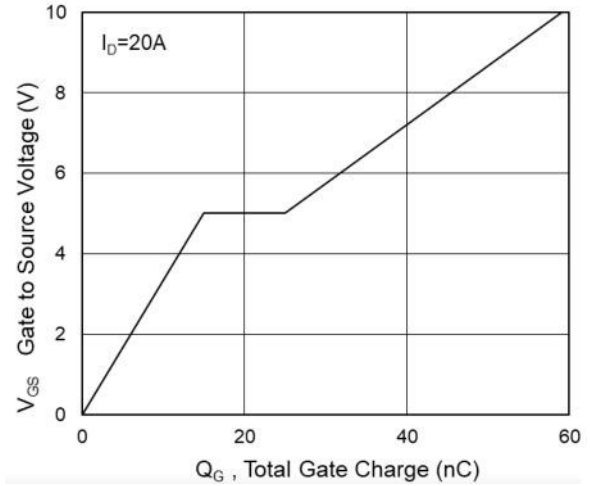

Figure 5. Body-Diode Characteristics

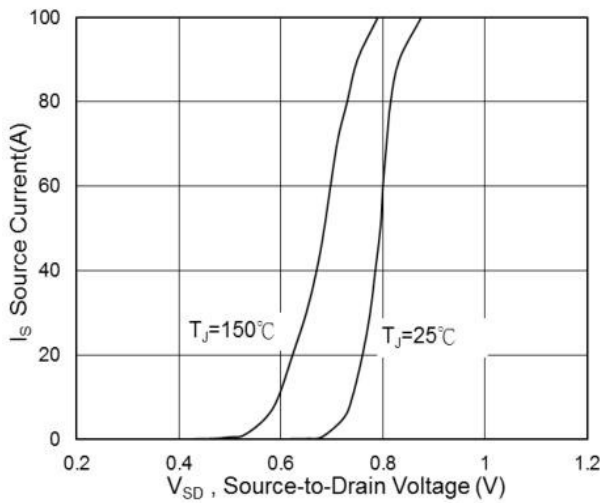

Figure 6. Rdson-Drain Current

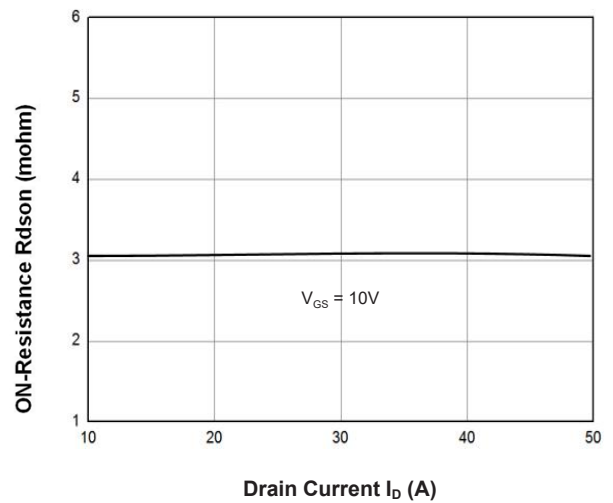

Figure 7. R<sub>ds(on)</sub>-Junction Temperature

 Figure 8. V<sub>GS(th)</sub>-Junction Temperature

Figure 9. On-Resistance vs. Gate-to-Source voltage

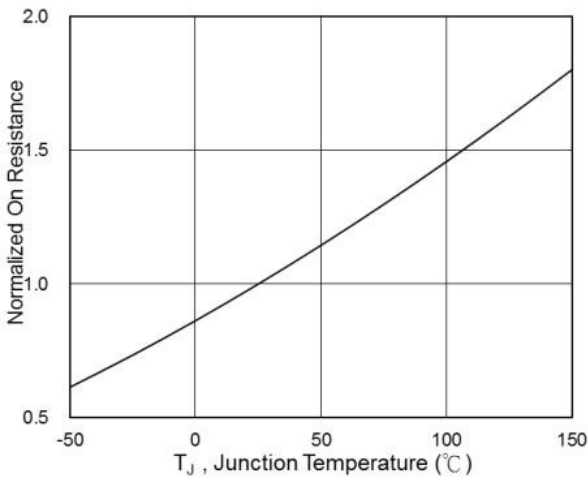
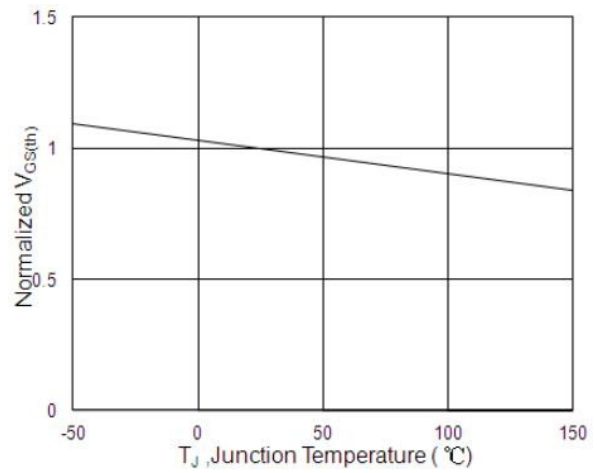
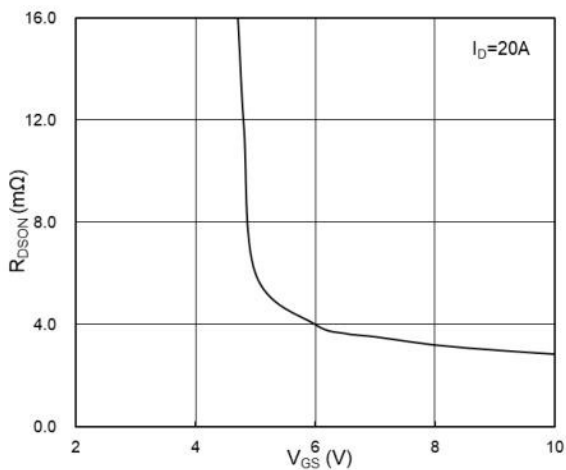
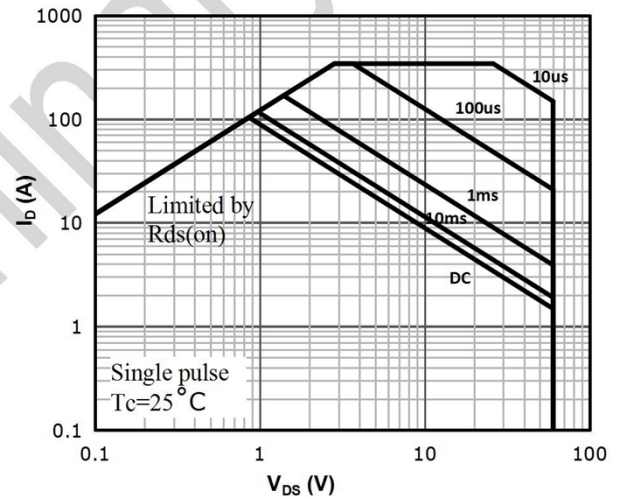
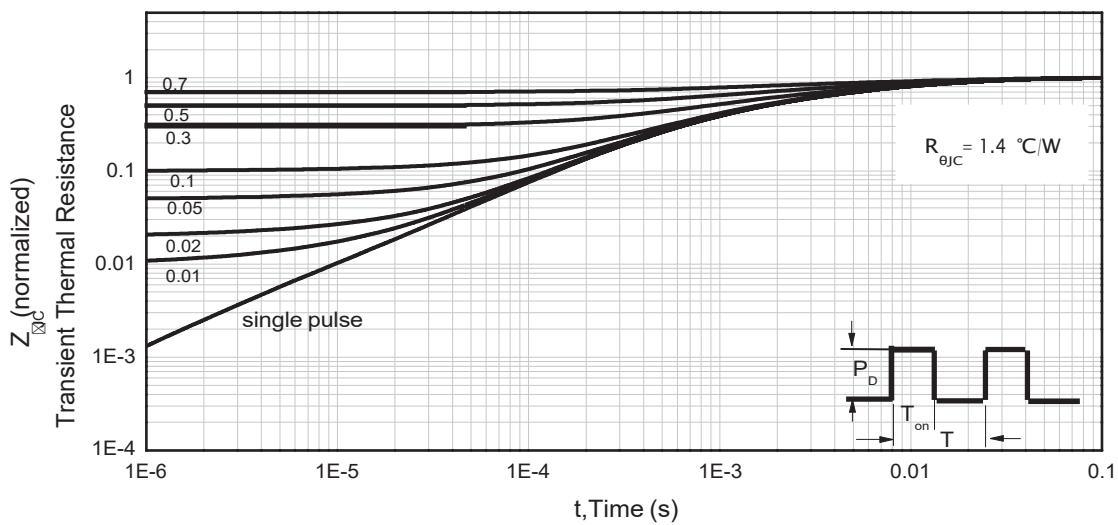
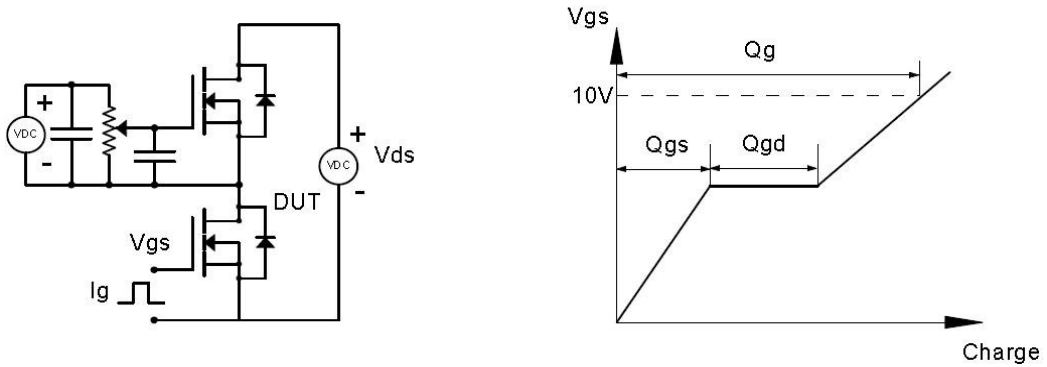
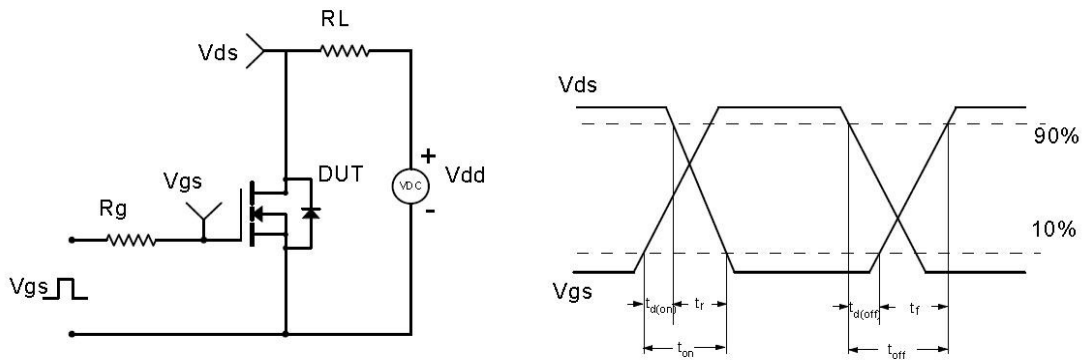
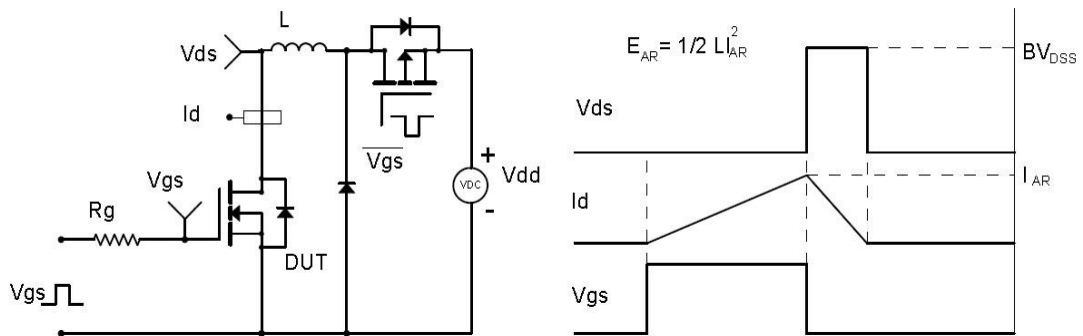

Figure 10: Safe Operating Area

 Figure 11. Normalized Maximum Transient Thermal Impedance (R<sub>thJC</sub>)

**Test Circuit & Waveform**
**Gate Charge Test Circuit & Waveform**

**Resistive Switching Test Circuit & Waveforms**

**Unclamped Inductive Switching (UIS) Test Circuit & Waveforms**

**Diode Recovery Test Circuit & Waveforms**
