

### Description

The VST10N072 uses **Super Trench** technology that is uniquely optimized to provide the most efficient high frequency switching performance. Both conduction and switching power losses are minimized due to an extremely low combination of  $R_{DS(ON)}$  and  $Q_g$ . This device is ideal for high-frequency switching and synchronous rectification.

### General Features

- $V_{DS} = 100V, I_D = 78A$   
 $R_{DS(ON)} = 7.2m\Omega$ (typical) @  $V_{GS} = 10V$   
 $R_{DS(ON)} = 9.5m\Omega$ (typical) @  $V_{GS} = 4.5V$
- Excellent gate charge x  $R_{DS(on)}$  product(FOM)
- Very low on-resistance  $R_{DS(on)}$
- 175 °C operating temperature
- Pb-free lead plating
- 100% UIS tested

### Application

- DC/DC Converter
- Ideal for high-frequency switching and synchronous rectification



TO-252

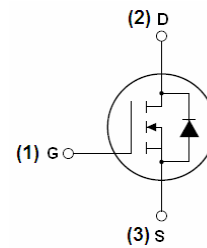

Schematic Diagram

### Package Marking and Ordering Information

Device Marking	Device	Device Package	Reel Size	Tape width	Quantity
VST10N072-T2	VST10N072	TO-252	-	-	-

### Absolute Maximum Ratings ( $T_C = 25^\circ C$ unless otherwise noted)

Parameter	Symbol	Limit	Unit
Drain-Source Voltage	$V_{DS}$	100	V
Gate-Source Voltage	$V_{GS}$	$\pm 20$	V
Drain Current-Continuous	$I_D$	78	A
Drain Current-Continuous( $T_C = 100^\circ C$ )	$I_D(100^\circ C)$	60	A
Pulsed Drain Current	$I_{DM}$	320	A
Maximum Power Dissipation	$P_D$	125	W
Derating factor		0.83	W/ $^\circ C$
Single pulse avalanche energy <sup>(Note 5)</sup>	$E_{AS}$	320	mJ
Operating Junction and Storage Temperature Range	$T_J, T_{STG}$	-55 To 175	$^\circ C$

**Thermal Characteristic**

Thermal Resistance, Junction-to-Case <sup>(Note 2)</sup>	$R_{\theta JC}$	1.2	$^{\circ}C/W$
--	-----------------	-----	---------------

**Electrical Characteristics ( $T_C=25^{\circ}C$  unless otherwise noted)**

Parameter	Symbol	Condition	Min	Typ	Max	Unit
<b>Off Characteristics</b>						
Drain-Source Breakdown Voltage	$BV_{DSS}$	$V_{GS}=0V, I_D=250\mu A$	100		-	V
Zero Gate Voltage Drain Current	$I_{DSS}$	$V_{DS}=100V, V_{GS}=0V$	-	-	1	$\mu A$
Gate-Body Leakage Current	$I_{GSS}$	$V_{GS}=\pm 20V, V_{DS}=0V$	-	-	$\pm 100$	nA
<b>On Characteristics</b> <sup>(Note 3)</sup>						
Gate Threshold Voltage	$V_{GS(th)}$	$V_{DS}=V_{GS}, I_D=250\mu A$	1.2	1.7	2.2	V
Drain-Source On-State Resistance	$R_{DS(on)}$	$V_{GS}=10V, I_D=39A$	-	7.2	8.5	m $\Omega$
		$V_{GS}=4.5V, I_D=39A$	-	9.5	12	m $\Omega$
Forward Transconductance	$g_{FS}$	$V_{DS}=10V, I_D=39A$	40	-	-	S
<b>Dynamic Characteristics</b> <sup>(Note 4)</sup>						
Input Capacitance	$C_{iss}$	$V_{DS}=50V, V_{GS}=0V,$ $F=1.0MHz$	-	4200	5480	PF
Output Capacitance	$C_{oss}$		-	354	425	PF
Reverse Transfer Capacitance	$C_{rss}$		-	23	30	PF
<b>Switching Characteristics</b> <sup>(Note 4)</sup>						
Turn-on Delay Time	$t_{d(on)}$	$V_{DD}=50V, I_D=39A$ $V_{GS}=10V, R_G=4.7\Omega$	-	15	-	nS
Turn-on Rise Time	$t_r$		-	10	-	nS
Turn-Off Delay Time	$t_{d(off)}$		-	41	-	nS
Turn-Off Fall Time	$t_f$		-	6	-	nS
Total Gate Charge	$Q_g$	$V_{DS}=50V, I_D=39A,$ $V_{GS}=10V$	-	65		nC
Gate-Source Charge	$Q_{gs}$		-	15.3		nC
Gate-Drain Charge	$Q_{gd}$		-	9		nC
<b>Drain-Source Diode Characteristics</b>						
Diode Forward Voltage <sup>(Note 3)</sup>	$V_{SD}$	$V_{GS}=0V, I_S=78A$	-		1.2	V
Diode Forward Current <sup>(Note 2)</sup>	$I_S$		-	-	78	A
Reverse Recovery Time	$t_{rr}$	$T_J = 25^{\circ}C, I_F = I_S$ $di/dt = 100A/\mu s$ <sup>(Note 3)</sup>	-	101		nS
Reverse Recovery Charge	$Q_{rr}$		-	193		nC

**Notes:**

1. Repetitive Rating: Pulse width limited by maximum junction temperature.
2. Surface Mounted on FR4 Board,  $t \leq 10$  sec.
3. Pulse Test: Pulse Width  $\leq 300\mu s$ , Duty Cycle  $\leq 2\%$ .
4. Guaranteed by design, not subject to production
5. EAS condition :  $T_J=25^{\circ}C, V_{DD}=50V, V_G=10V, L=0.5mH, R_g=25\Omega$

**Test Circuit**
**1) E<sub>AS</sub> test Circuit**

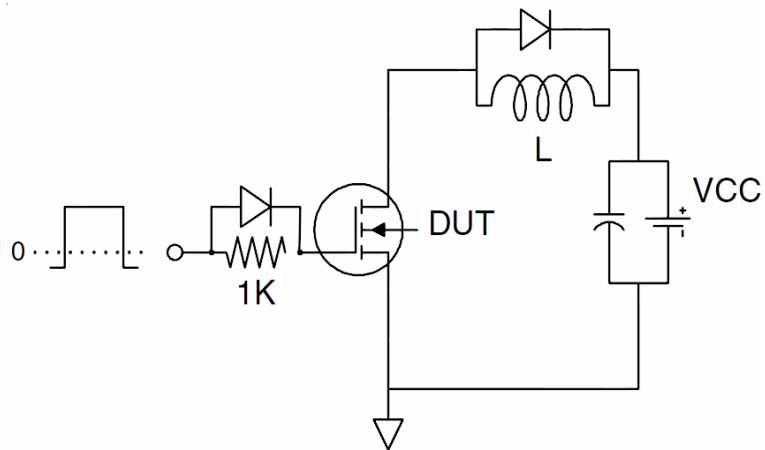
**2) Gate charge test Circuit**

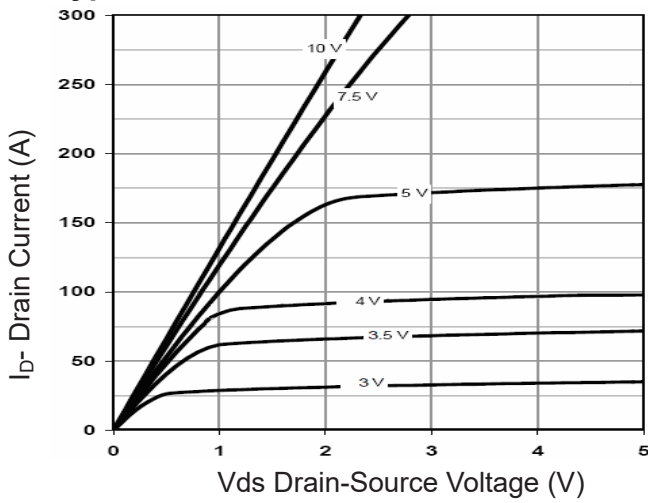
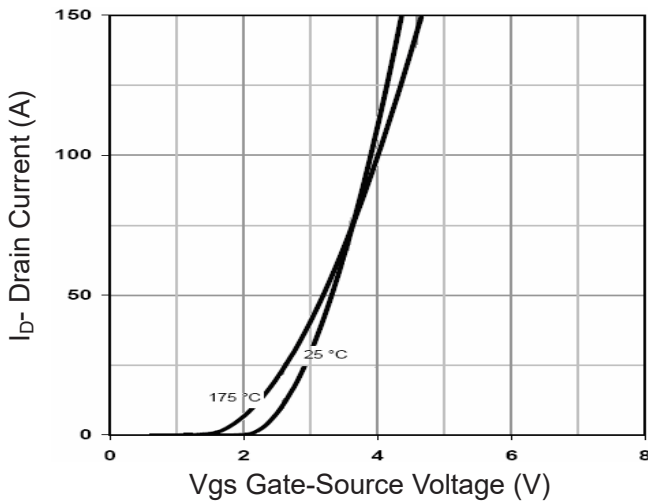
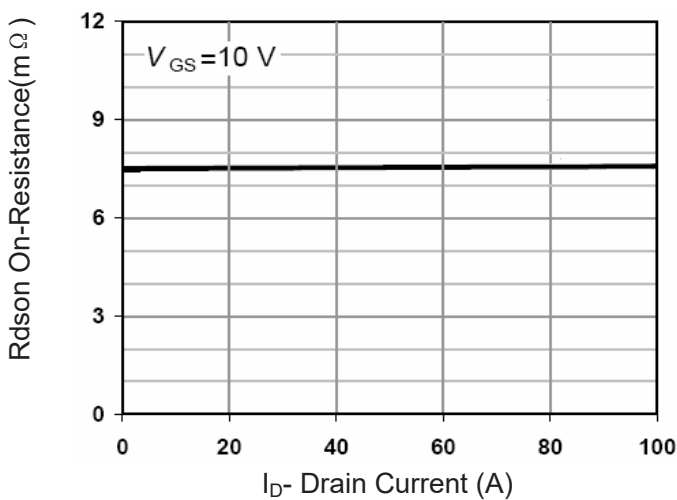
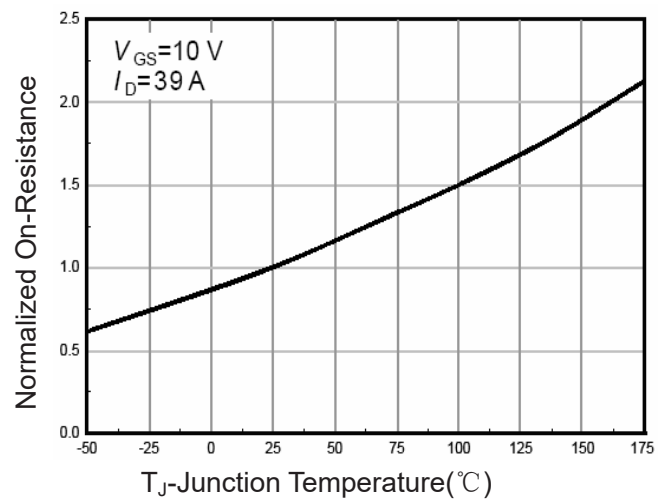
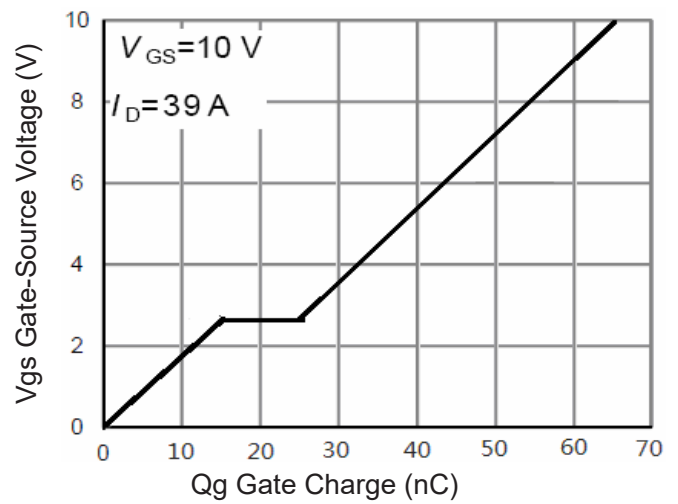
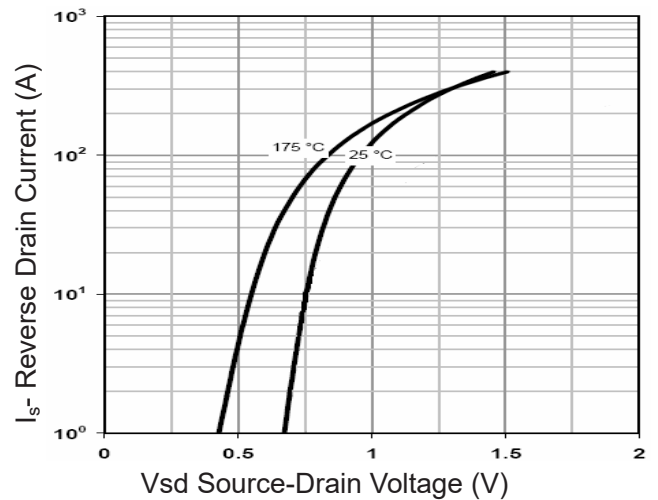
**3) Switch Time Test Circuit**

**Typical Electrical and Thermal Characteristics**

**Figure 1 Output Characteristics**

**Figure 2 Transfer Characteristics**

**Figure 3 Rds(on)- Drain Current**

**Figure 4 Rds(on)-Junction Temperature**

**Figure 5 Gate Charge**

**Figure 6 Source- Drain Diode Forward**

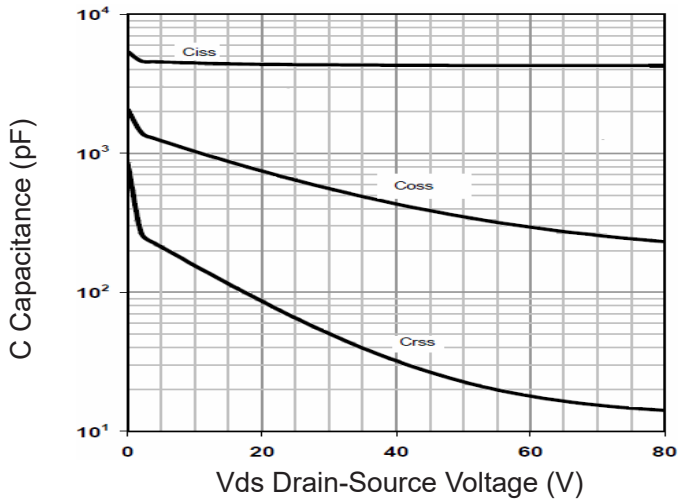

Figure 7 Capacitance vs Vds

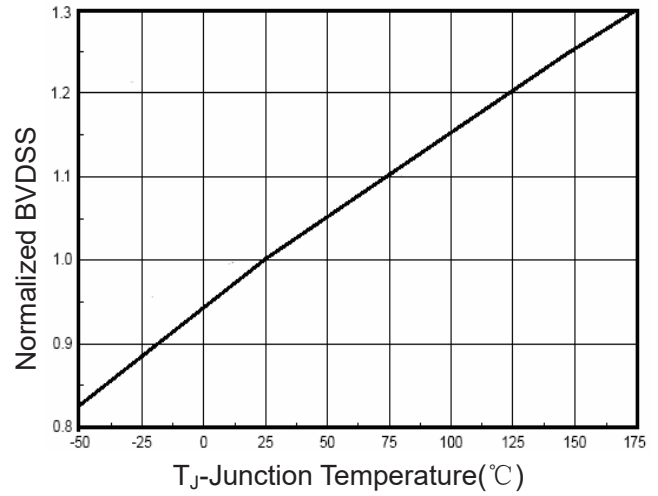

Figure 9  $BV_{DSS}$  vs Junction Temperature

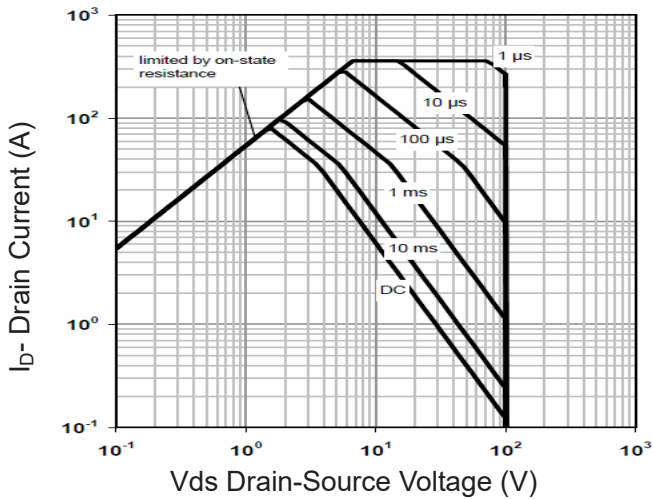

Figure 8 Safe Operation Area

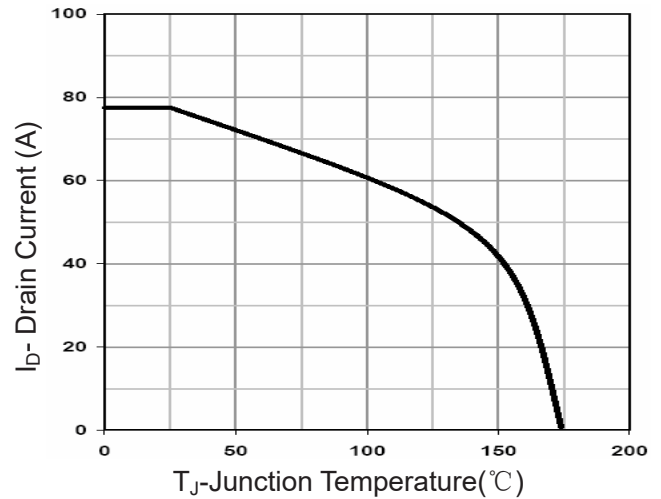

Figure 10 Current De-rating

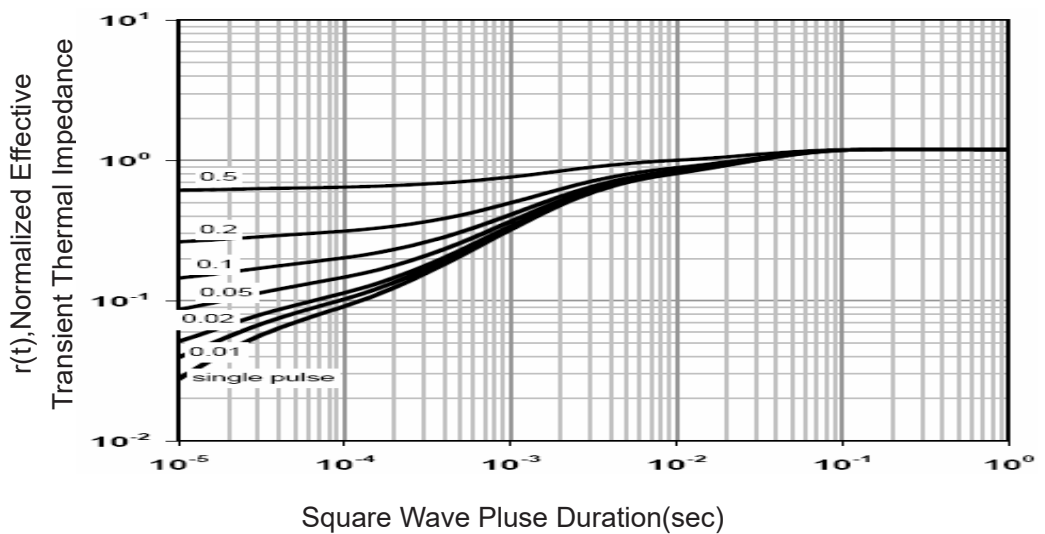

Figure 11 Normalized Maximum Transient Thermal Impedance